



# SN74LS724

## Advance Information

### VOLTAGE CONTROLLED OSCILLATOR

**DESCRIPTION** — The SN74LS724 is a low power Voltage Controlled Oscillator. With an external capacitor connected across Pins 1 and 8, the output frequency can be varied over a 3.5 to 1 range by adjusting the control voltage input ( $V_{in}$ ) from 1.0 to 5.0 volts.

The LS724 is ideal for video game and microcomputer applications. It can be used to generate sound IF, a colorburst reference, and/or a microprocessor clock. Also, the output rise and fall times are slow compared to standard LS logic so the generation of electromagnetic interference is reduced.

**FEATURES:**

- CAN BE USED AS A VOLTAGE CONTROLLED OR CRYSTAL CONTROLLED OSCILLATOR
- 8-PIN DIP REQUIRES MINIMAL PC BOARD SPACE
- REDUCED RISE AND FALL TIMES FOR LESS EMI
- LOW POWER — 45 mW MAX

### VOLTAGE-CONTROLLED OSCILLATOR

LOW POWER SCHOTTKY

### CONNECTION DIAGRAM DIP (TOP VIEW)

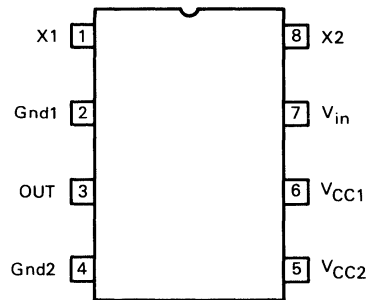

Case 626-04 (Plastic)  
Case 693-02 (Ceramic)

### VOLTAGE CONTROLLED MULTIVIBRATOR

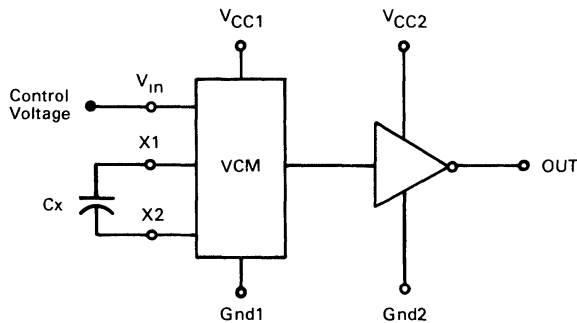

### CRYSTAL OSCILLATOR

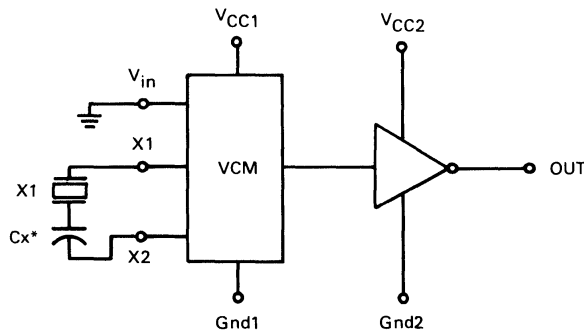

\*Cx is optional

(Cx may be necessary to trim oscillator frequency or improve performance.)

This document contains information on a new product. Specifications and information herein are subject to change without notice.

**GUARANTEED OPERATING RANGES**

SYMBOL	PARAMETER	MIN	TYP	MAX	UNIT
V <sub>CC</sub>	Supply Voltage	4.75	5.0	5.25	V
T <sub>A</sub>	Operating Ambient Temperature Range	0	25	70	°C
I <sub>OH</sub>	Output Current — High			-0.4	mA
I <sub>OL</sub>	Output Current — Low			4.0	mA

**DC CHARACTERISTICS OVER OPERATING TEMPERATURE RANGE** (unless otherwise specified)

SYMBOL	PARAMETER	LIMITS			CONDITIONS
		MIN	MAX	UNITS	
V <sub>OH</sub>	Output HIGH Voltage	2.7		V	I <sub>OH</sub> = -0.4 mA, V <sub>CC</sub> = MIN
V <sub>OL</sub>	Output LOW Voltage		0.5	V	I <sub>OL</sub> = 4.0 mA, V <sub>CC</sub> = MIN
I <sub>IN</sub>	Input HIGH Current		100	μA	V <sub>IN</sub> = 5.0 V, V <sub>CC</sub> = MAX
I <sub>OS</sub>	Short Circuit Current	-8.0	-25	mA	V <sub>O</sub> = 0 V, V <sub>CC</sub> = MAX
I <sub>CC</sub>	Supply Current		8.5	mA	V <sub>CC</sub> = MAX

4

**AC CHARACTERISTICS:** V<sub>CC</sub> = 5.0 V, T<sub>A</sub> = 25°C, C<sub>L</sub> = 15 pF

SYMBOL	TEST	CONDITIONS	VALUE			UNITS
			MIN	TYP	MAX	
f <sub>max</sub> *	Maximum Operating Frequency	C <sub>x</sub> = 10 pF, V <sub>IN</sub> = 5.0 Vdc V <sub>CC</sub> = 5.0 Vdc Load = 15 pF	11	16		MHz
f <sub>HIGH</sub> f <sub>LOW</sub>	Ratio of Frequency of Oscillation Over Specified Input Voltage Range	C <sub>x</sub> = 100 pF V <sub>IN</sub> HIGH = 5.0 Vdc V <sub>IN</sub> LOW = 1.0 Vdc	3.5 to 1.0	4.0 to 1.0		—

\*Due to the low power nature of this device, some degradation of output swing can be expected as output frequency exceeds 9.0 MHz. With V<sub>CC</sub> = 5.0 V, the guaranteed V<sub>OH</sub> level drops from 2.7 volts at 9.0 MHz to 2.0 volts at 16 MHz.

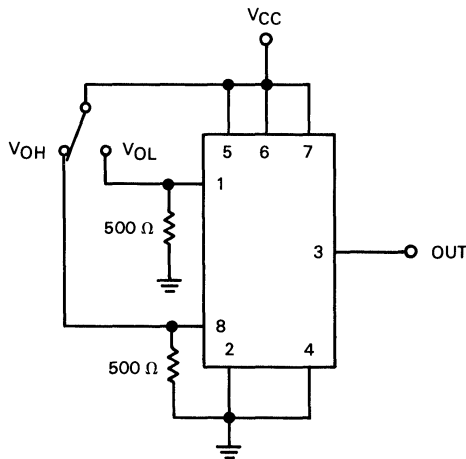

For dc test purposes the LS724 output can be forced into a HIGH (V<sub>OH</sub>) or LOW (V<sub>OL</sub>) logic state as shown.

**APPLICATIONS INFORMATION**

In order to improve frequency stability, separate  $V_{CC}$  and ground pins are provided to allow the oscillator to be isolated from the logic power supply. However, both ground lines must be connected externally to ensure proper operation. It is also recommended that the oscillator  $V_{CC}$  be bypassed with a good RF type capacitor of 500 to 1000 pF.

When used as a voltage controlled oscillator, the center frequency can be approximated by:

$$f_c \text{ (MHz)} \approx \frac{130}{C_x \text{ (pF)}} : V_{in} \approx 4.25 \text{ V}$$

The relationship between control input voltage, external capacitance and output frequency can be found in Figure 1 which is valid for values of capacitance in excess of 100 pF. For values of capacitance less than 100 pF, Figure 2 should be used.

**FREQUENCY STABILITY**

Oscillator output frequency is somewhat dependent on temperature and power supply voltage. Typical frequency variation at  $V_{in} = 5.0 \text{ V}$  is approximately  $\pm 10\%$  over the  $V_{CC}$  range and approximately  $\pm 7\%$  over the  $0^\circ\text{C}$  to  $70^\circ\text{C}$  temperature range. As with any oscillator, internal noise will also cause the output frequency to drift slightly.

**FIGURE 1 — FREQUENCY CAPACITANCE PRODUCT**

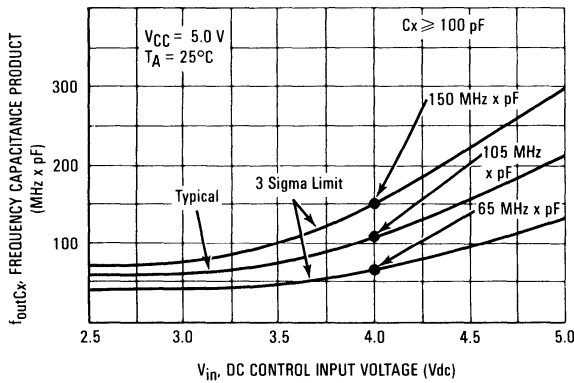

**FIGURE 2 — FREQUENCY CAPACITANCE PRODUCT TYPICAL CURVES**

