

# TYPES SN54LS445, SN74LS445 BCD-TO-DECIMAL DECODERS/DRIVERS

D2427, NOVEMBER 1977—REVISED DECEMBER 1983

FOR USE AS LAMP, RELAY, OR MOS DRIVERS

- Low-Voltage Version of SN54LS145/SN74LS145
- Full Decoding of Input Logic
- SN74LS445 Has 80-mA Sink-Current Capability
- All Outputs Are Off for Invalid BCD Input Conditions
- Low Power Dissipation . . . 35 mW Typical

logic

FUNCTION TABLE

NO.	INPUTS				OUTPUTS										
	D	C	B	A	0	1	2	3	4	5	6	7	8	9	
0	L	L	L	L	L	H	H	H	H	H	H	H	H	H	H
1	L	L	L	H	H	L	H	H	H	H	H	H	H	H	H
2	L	L	H	L	H	H	L	H	H	H	H	H	H	H	H
3	L	L	H	H	H	H	H	L	H	H	H	H	H	H	H
4	L	H	L	L	H	H	H	H	L	H	H	H	H	H	H
5	L	H	L	H	H	H	H	H	H	L	H	H	H	H	H
6	L	H	H	L	H	H	H	H	H	H	L	H	H	H	H
7	L	H	H	H	H	H	H	H	H	H	H	L	H	H	H
8	H	L	L	L	H	H	H	H	H	H	H	H	L	H	H
9	H	L	L	H	H	H	H	H	H	H	H	H	H	L	H
INVALID	H	L	H	L	H	H	H	H	H	H	H	H	H	H	H
	H	L	H	H	H	H	H	H	H	H	H	H	H	H	H
	H	H	L	L	H	H	H	H	H	H	H	H	H	H	H
	H	H	L	H	H	H	H	H	H	H	H	H	H	H	H
	H	H	H	L	H	H	H	H	H	H	H	H	H	H	H

H = high level (off), L = low level (on)

## description

These monolithic BCD-to-decimal decoder/drivers consist of eight inverters and ten four-input NAND gates. The inverters are connected in pairs to make BCD input data available for decoding by the NAND gates. Full decoding of valid BCD input logic ensures that all outputs remain off for all invalid binary input conditions. These decoders feature high-performance, n-p-n output transistors designed for use as indicator/relay drivers or as open-collector logic-circuit drivers. Each of the output transistors will sink up to 80 milliamperes of current. Each input is one Series 54LS/74LS standard load. Inputs and outputs are entirely compatible for use with TTL logic circuits, and the outputs are compatible for interfacing with most MOS integrated circuits. Power dissipation is typically 35 milliwatts.

## PRODUCTION DATA

This document contains information current as of publication date. Products conform to specifications per the terms of Texas Instruments standard warranty. Production processing does not necessarily include testing of all parameters.

**TEXAS  
INSTRUMENTS**

POST OFFICE BOX 225012 • DALLAS, TEXAS 75265

SN54LS445 . . . J PACKAGE  
SN74LS445 . . . D, J OR N PACKAGE  
(TOP VIEW)

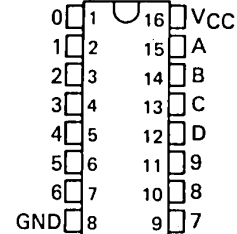

SN54LS445 . . . FK PACKAGE  
SN74LS445 . . . FN PACKAGE  
(TOP VIEW)

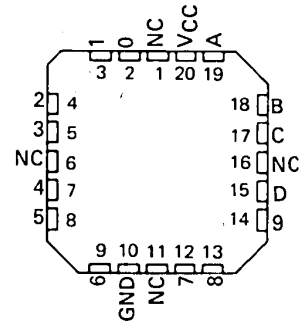

NC - No internal connection

## logic diagram

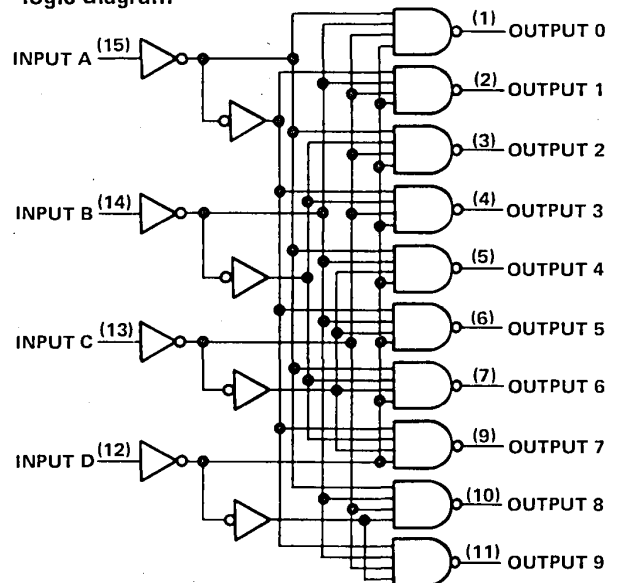

Pin numbers shown on logic notation are for D, J or N packages.



TTL DEVICES

# TYPES SN54LS445, SN74LS445 BCD-TO-DECIMAL DECODERS/DRIVERS

absolute maximum ratings over operating free-air temperature range (unless otherwise noted)

Supply voltage, $V_{CC}$ (see Note 1)	7 V
Input voltage	7 V
Operating free-air temperature range: SN54LS445	-55°C to 125°C
SN74LS445	0°C to 70°C
Storage temperature range	-65°C to 150°C

NOTE 1: Voltage values are with respect to network ground terminal.

### recommended operating conditions

	SN54LS445			SN74LS445			UNIT
	MIN	NOM	MAX	MIN	NOM	MAX	
Supply voltage, $V_{CC}$	4.5	5	5.5	4.75	5	5.25	V
Off-state output voltage, $V_{O(off)}$	7			7			V
Operating free-air temperature, $T_A$	-55	125		0	70		°C

electrical characteristics over recommended operating free-air temperature range (unless otherwise noted)

PARAMETER	TEST CONDITIONS†	SN54LS445			SN74LS445			UNIT	
		MIN	TYP‡	MAX	MIN	TYP‡	MAX		
$V_{IH}$ High-level input voltage		2			2			V	
$V_{IL}$ Low-level input voltage				0.7			0.8	V	
$V_{IK}$ Input clamp voltage	$V_{CC} = \text{MIN}, I_I = -18 \text{ mA}$			-1.5			-1.5	V	
$I_{O(off)}$ Off-state output current	$V_{CC} = \text{MIN}, V_{IH} = 2 \text{ V}, V_{IL} = V_{IL \text{ max}}, V_{OH} = 7 \text{ V}$			250			250	$\mu\text{A}$	
$V_{O(on)}$ On-state output voltage	$V_{CC} = \text{MIN}, V_{IH} = 2 \text{ V}, V_{IL} = V_{IL \text{ max}}$	$I_{OL} = 12 \text{ mA}$	0.25	0.4	0.25	0.4	V		
		$I_{OL} = 24 \text{ mA}$			0.35	0.5			
		$I_{OL} = 80 \text{ mA}$			2.3	3			
$I_I$ Input current at maximum input voltage	$V_{CC} = \text{MAX}, V_I = 7 \text{ V}$			0.1			0.1	mA	
$I_{IH}$ High-level input current	$V_{CC} = \text{MAX}, V_I = 2.7 \text{ V}$			20			20	$\mu\text{A}$	
$I_{IL}$ Low-level input current	$V_{CC} = \text{MAX}, V_I = 0.4 \text{ V}$			-0.4			-0.4	mA	
$I_{CC}$ Supply current	$V_{CC} = \text{MAX},$ See Note 2			7	13		7	13	mA

† For conditions shown as MIN or MAX, use the appropriate value specified under recommended operating conditions.

‡ All typical values are at  $V_{CC} = 5 \text{ V}, T_A = 25^\circ\text{C}$ .

NOTE 2:  $I_{CC}$  is measured with all inputs grounded and outputs open.

switching characteristics,  $V_{CC} = 5 \text{ V}, T_A = 25^\circ\text{C}$

PARAMETER	TEST CONDITIONS	MIN	MAX	UNIT
$t_{PLH}$ Propagation delay time, low-to-high-level output	$C_L = 45 \text{ pF}, R_L = 665 \Omega,$ See Note 3		50	ns
$t_{PHL}$ Propagation delay time, high-to-low-level output			50	ns

NOTE 3: See General Information Section for load circuits and voltage waveforms.

### logic symbol

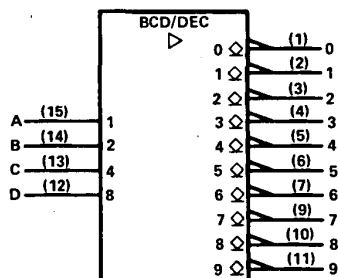

Pin numbers shown on logic notation are for D, J or N packages.

### schematic of inputs and outputs

