

# TYPES SN54116, SN74116 DUAL 4-BIT LATCHES WITH CLEAR

DECEMBER 1972—REVISED DECEMBER 1983

- Two Independent 4-Bit Latches in a Single Package
- Separate Clear Inputs Provide One-Step Clearing Operation
- Dual Gated Enable Inputs Simplify Cascading Register Implementations
- Compatible for Use with TTL Circuits
- Input Clamping Diodes Simplify System Design

SN54116 . . . J OR W PACKAGE  
SN74116 . . . J OR N PACKAGE  
(TOP VIEW)

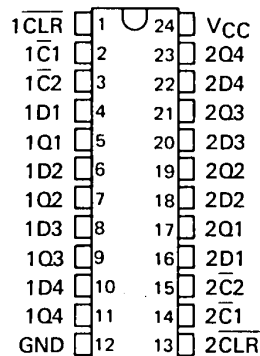

## description

These monolithic TTL circuits utilize D-type bistables to implement two independent four-bit latches in a single package. Each four-bit latch has an independent asynchronous clear input and a gated two-input enable circuit. When both enable inputs are low, the output levels will follow the data input levels. When either or both of the enable inputs are taken high, the outputs remain at the last levels setup at the inputs prior to the low-to-high-level transition at the enable input(s). After this, the data inputs are locked out.

The clear input is overriding and when taken low will reset all four outputs low regardless of the levels of the enable inputs.

The SN54116 is characterized for operation over the full military temperature range of  $-55^{\circ}\text{C}$  to  $125^{\circ}\text{C}$ ; the SN74116 is characterized for operation from  $0^{\circ}\text{C}$  to  $70^{\circ}\text{C}$ .

FUNCTION TABLE  
(EACH LATCH)

CLEAR	ENABLE		DATA	OUTPUT Q
	$\overline{\text{C1}}$	$\overline{\text{C2}}$		
H	L	L	L	L
H	L	L	H	H
H	X	H	X	$Q_0$
H	H	X	X	$Q_0$
L	X	X	X	L

H = high level, L = low level, X = irrelevant  
 $Q_0$  = the level of Q before these input conditions were established.

## PRODUCTION DATA

This document contains information current as of publication date. Products conform to specifications per the terms of Texas Instruments standard warranty. Production processing does not necessarily include testing of all parameters.

TEXAS  
INSTRUMENTS

POST OFFICE BOX 225012 • DALLAS, TEXAS 75265

3-461

3

TTL DEVICES

# TYPES SN54116, SN74116 DUAL 4-BIT LATCHES WITH CLEAR

logic diagram

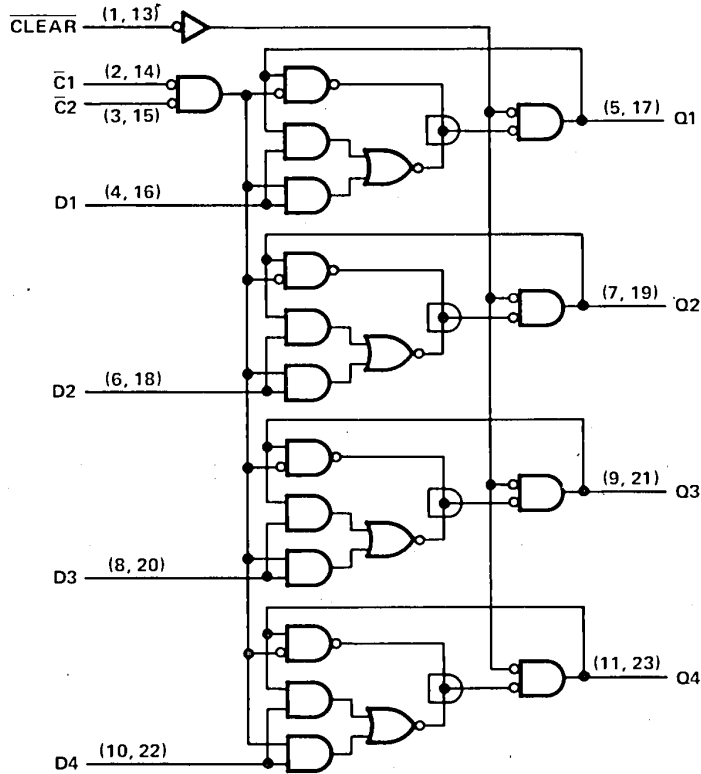

Pin numbers shown on logic notation are for J or N packages.

schematics of inputs and outputs

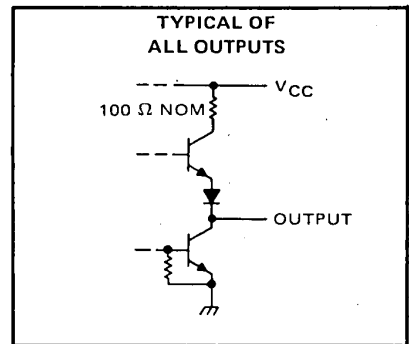
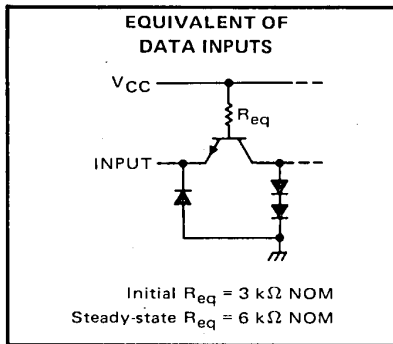
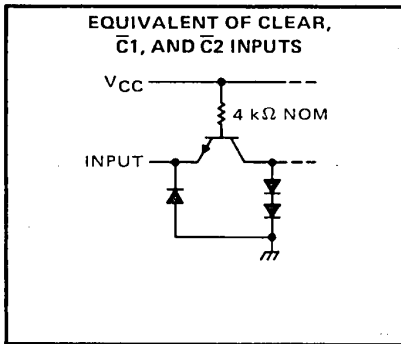

absolute maximum ratings over operating free-air temperature range (unless otherwise noted)

Supply voltage, $V_{CC}$ (see Note 1)	7 V
Input voltage	5.5 V
Operating free-air temperature range: SN54116 Circuits	-55°C to 125°C
SN74116 Circuits	0°C to 70°C
Storage temperature range	-65°C to 150°C

NOTE 1: Voltage values are with respect to network ground terminal.

3

TTL DEVICES

TYPES SN54116, SN74116  
DUAL 4-BIT LATCHES WITH CLEAR

recommended operating conditions

	SN54116			SN74116			UNIT
	MIN	NOM	MAX	MIN	NOM	MAX	
Supply voltage, $V_{CC}$	4.5	5	5.5	4.75	5	5.25	V
High-level output current, $I_{OH}$	-800			-800			$\mu$ A
Low-level output current, $I_{OL}$	16			16			mA
Input pulse width, $t_w$	$\bar{C}1, \bar{C}2$	18		18		ns	
	$\bar{CLR}$	18		18			
Data setup time, $t_{SU}$	High logic level	8		8		ns	
	Low logic level	14		14			
Clear inactive-state setup time, $t_{SU}$	8		8		ns		
Data release time, high-level data, $t_{release}$	2			2			ns
Data hold time, low-level data, $t_H$	8			8			ns
Operating free-air temperature, $T_A$	-55	125		0	70		$^{\circ}$ C

electrical characteristics over recommended operating free-air temperature range (unless otherwise noted)

PARAMETER		TEST CONDITIONS <sup>†</sup>	MIN	TYP <sup>‡</sup>	MAX	UNIT
$V_{IH}$	High-level input voltage		2			V
$V_{IL}$	Low-level input voltage		0.8			V
$V_{IK}$	Input clamp voltage	$V_{CC} = \text{MIN}, I_I = -12 \text{ mA}$	-1.5			V
$V_{OH}$	High-level output voltage	$V_{CC} = \text{MIN}, V_{IH} = 2 \text{ V}, V_{IL} = 0.8 \text{ V}, I_{OH} = -800 \mu\text{A}$	2.4	3.4		V
$V_{OL}$	Low-level output voltage	$V_{CC} = \text{MIN}, V_{IH} = 2 \text{ V}, V_{IL} = 0.8 \text{ V}, I_{OL} = 16 \text{ mA}$	0.2	0.4		V
$I_I$	Input current at maximum input voltage	$V_{CC} = \text{MAX}, V_I = 5.5 \text{ V}$	1			mA
$I_{IH}$	High-level input current	$\bar{C}1, \bar{C}2, \text{ or clear}$	$V_{CC} = \text{MAX}, V_I = 2.4 \text{ V}$		40	$\mu$ A
		Any D			60	
$I_{IL}$	Low-level input current	$\bar{C}1, \bar{C}2, \text{ or clear}$	$V_{CC} = \text{MAX}, V_I = 0.4 \text{ V}$		-1.6	mA
		Any D, initial peak			-2.4	
		Any D, steady-state			-1.6	
$I_{OS}$	Short-circuit output current <sup>§</sup>	$V_{CC} = \text{MAX}$	SN54116	-20	-57	mA
$I_{CC}$	Supply current	$V_{CC} = \text{MAX},$ See Note 2	SN74116	-18	-57	mA
			Condition A	60	100	mA
			Condition B	40	70	mA

<sup>†</sup>For conditions shown as MIN or MAX, use the appropriate value specified under recommended operating conditions for the applicable device type.

<sup>‡</sup>All typical values are at  $V_{CC} = 5 \text{ V}, T_A = 25^{\circ}\text{C}$ .

<sup>§</sup>Not more than one output should be shorted at a time.

NOTE 2: With outputs open,  $I_{CC}$  is measured for the following conditions:

- A. All inputs grounded.
- B. All  $\bar{C}$  inputs are grounded and all other inputs are at 4.5 V.

switching characteristics,  $V_{CC} = 5 \text{ V}, T_A = 25^{\circ}\text{C}$

PARAMETER	FROM (INPUT)	TO (OUTPUT)	TEST CONDITIONS	MIN	TYP	MAX	UNIT
$t_{PLH}$	$\bar{C}1 \text{ or } \bar{C}2$	Any Q	$C_L = 15 \text{ pF},$ $R_L = 400 \Omega,$ See Figure 1	19	30	ns	
$t_{PHL}$				15	22		
$t_{PLH}$	Data	Q		10	15	ns	
$t_{PHL}$				12	18		
$t_{PHL}$	$\bar{CLR}$	Any Q		15	22	ns	

TYPES SN54116, SN74116  
DUAL 4-BIT LATCHES WITH CLEAR

PARAMETER MEASUREMENT INFORMATION

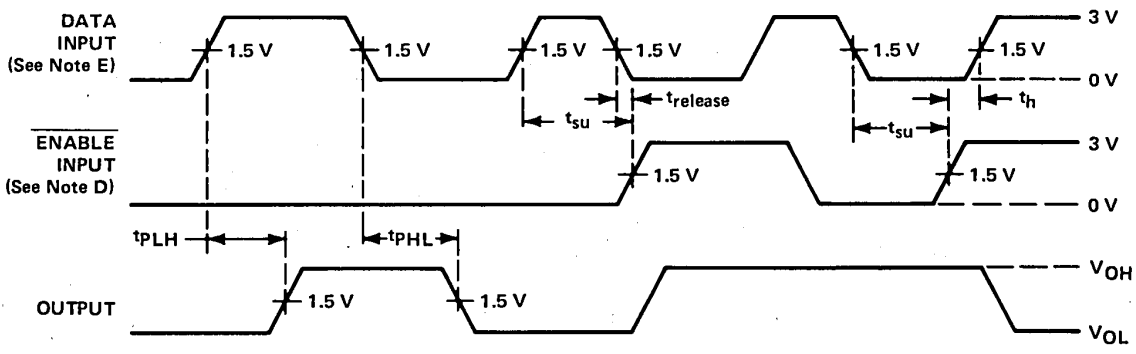
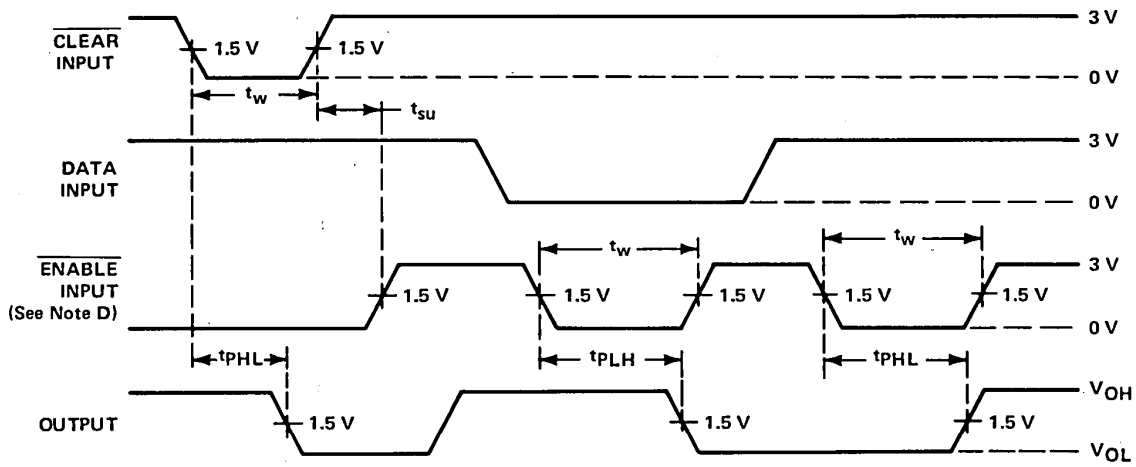
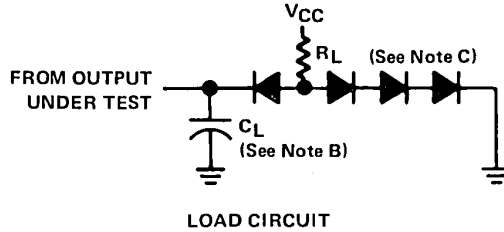

- NOTES: A. Input pulses are supplied by generators having the following characteristics:  $t_r \leq 10 \text{ ns}$ ,  $t_f \leq 10 \text{ ns}$ ,  $\text{PRR} = 1 \text{ MHz}$ , duty cycle  $\leq 50\%$ ,  $Z_{\text{out}} \approx 50\Omega$ .  
 B.  $C_L$  includes probe and jig capacitance.  
 C. All diodes are 1N3064 or equivalent.  
 D. The other enable input is low.  
 E. Clear input is high.

FIGURE 1

3

TTL DEVICES