

TYPES SN5442A THRU SN5444A, SN54L42 THRU SN54L44,
SN54LS42, SN7442A THRU SN7444A, SN74LS42
4-LINE TO 10-LINE DECODERS (1-OF-10)

MARCH 1974 — REVISED APRIL 1985

'42A, 'L42, 'LS42 . . . BCD-TO-DECIMAL
'43A, 'L43 . . . EXCESS-3-TO-DECIMAL
'44A, 'L44 . . . GRAY-TO-DECIMAL

- All Outputs Are High for Invalid Input Conditions
- Also for Application as
4-Line-to-16-Line Decoders
3-Line-to-8-Line Decoders
- Diode-Clamped Inputs

SN5442A THRU SN5444A, SN54LS42 . . . J OR W PACKAGE
SN54L42 THRU SN54L44 . . . J PACKAGE
SN7442A THRU SN7444A . . . J OR N PACKAGE
SN74LS42 . . . D, J OR N PACKAGE

(TOP VIEW)

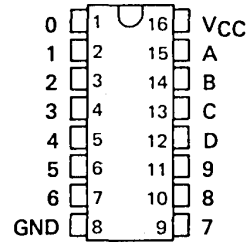

TYPES	TYPICAL POWER DISSIPATION	TYPICAL PROPAGATION DELAYS
'42A, '43A, '44A	140 mW	17 ns
'L42, 'L43, 'L44	70 mW	49 ns
'LS42	35 mW	17 ns

description

These monolithic decimal decoders consist of eight inverters and ten four-input NAND gates. The inverters are connected in pairs to make BCD input data available for decoding by the NAND gates. Full decoding of valid input logic ensures that all outputs remain off for all invalid input conditions.

The '42A, 'L42, and 'LS42 BCD-to-decimal decoders, the '43A and 'L43 excess-3-to-decimal decoders, and the '44A and 'L44 gray-to-decimal decoders feature inputs and outputs that are compatible for use with most TTL and other saturated low-level logic circuits. DC noise margins are typically one volt.

Series 54, 54L, and 54LS circuits are characterized for operation over the full military temperature range of -55°C to 125°C; Series 74, and 74LS circuits are characterized for operation from 0°C to 70°C.

SN54LS42 . . . FK PACKAGE
SN74LS42 . . . FN PACKAGE

(TOP VIEW)

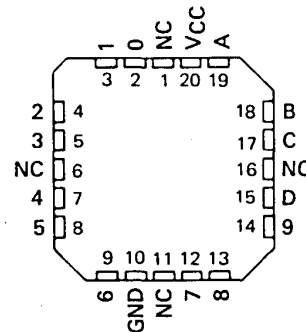

NC - No internal connection



TTL DEVICES

PRODUCTION DATA

This document contains information current as of publication date. Products conform to specifications per the terms of Texas Instruments standard warranty. Production processing does not necessarily include testing of all parameters.



POST OFFICE BOX 225012 • DALLAS, TEXAS 75265

TYPES SN5442A, SN54L42, SN54LS42, SN7442A, SN74LS42
 4-LINE TO 10-LINE DECODERS (1-OF-10)

logic diagrams

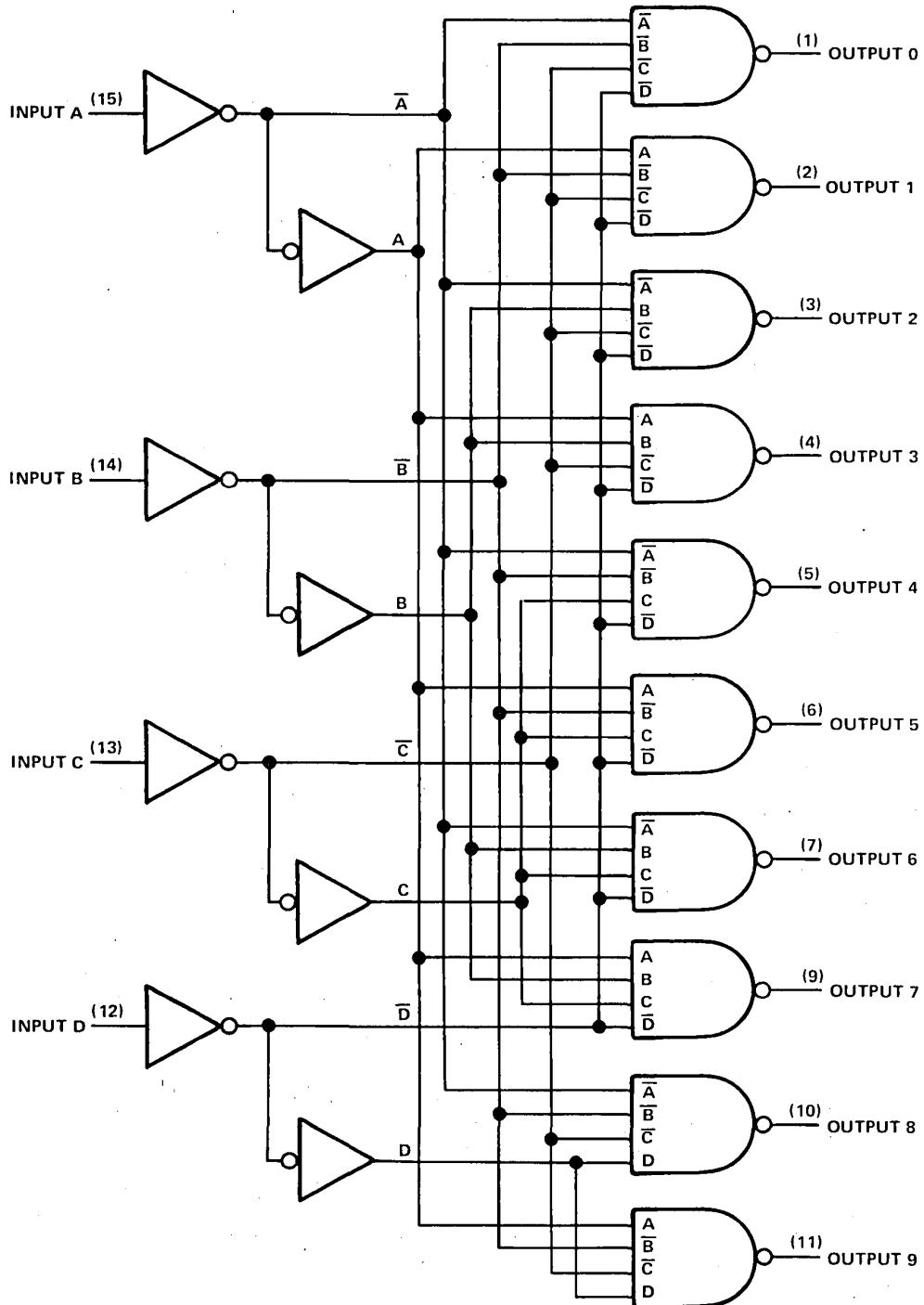

Pin numbers shown on logic notation are for D, J or N packages.

3 TTL DEVICES

TYPES SN5443A, SN54L43, SN7443A
4-LINE TO 10-LINE DECODERS (1-OF-10)

logic diagrams (continued)

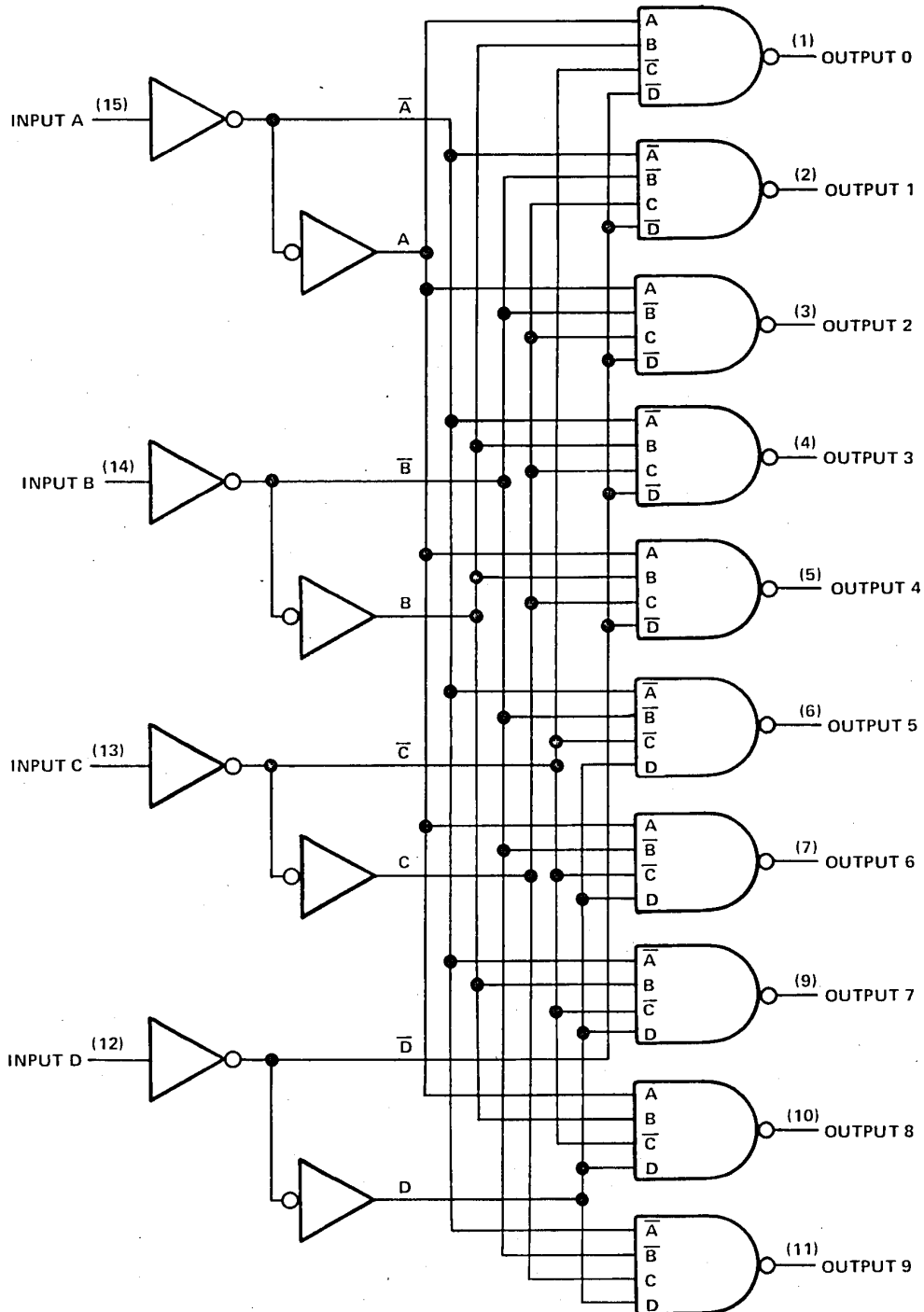

Pin numbers shown on logic notation are for D, J or N packages.

3
TTL DEVICES

TYPES SN5444A, SN54L44, SN7444A
4-LINE TO 10-LINE DECODERS (1-OF-10)

logic diagrams (continued)

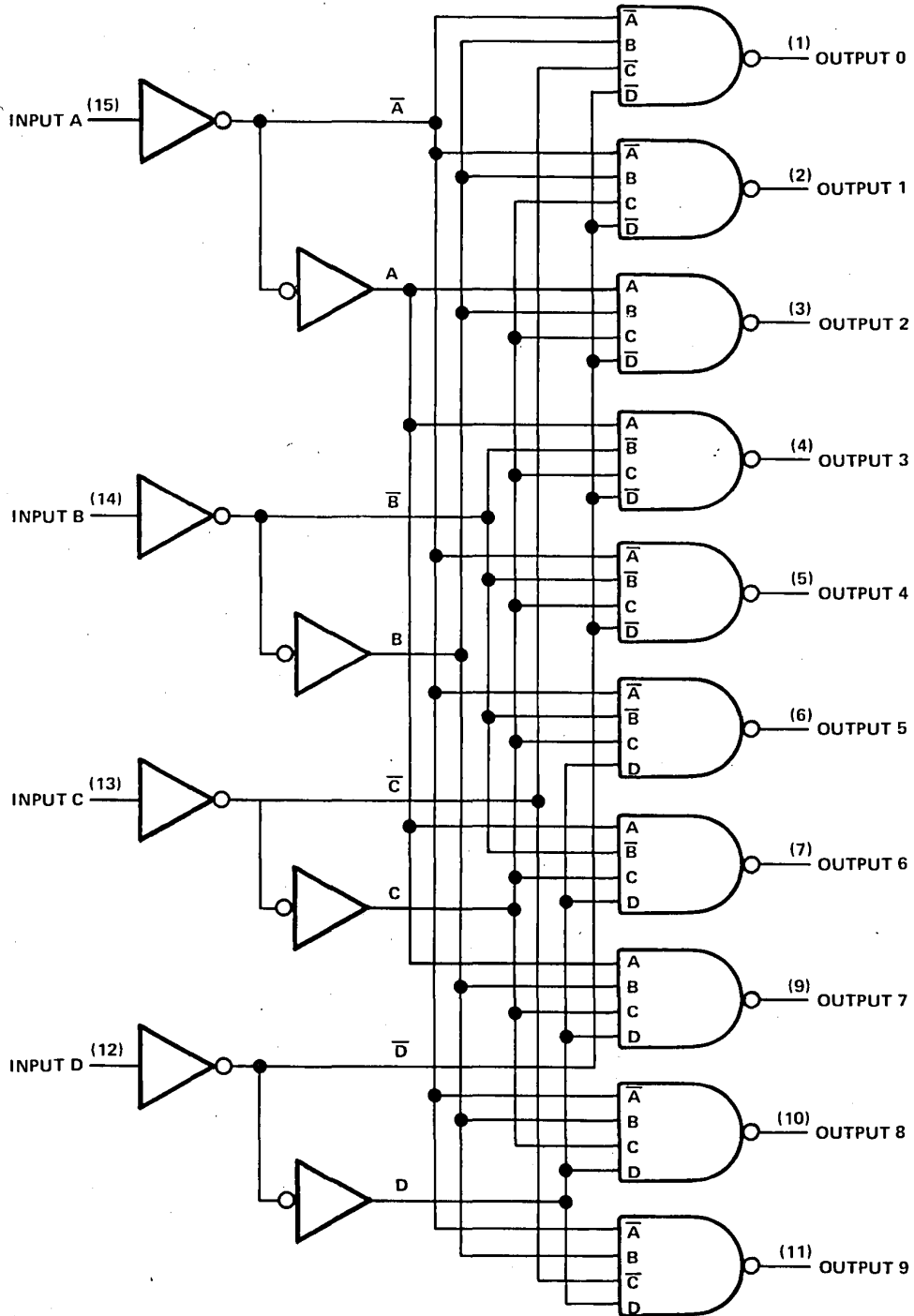

Pin numbers shown on logic notation are for D, J or N packages.

3

TTL DEVICES

TYPES SN5442A THRU SN5444A, SN54L42 THRU SN54L44,
SN54LS42, SN7442A THRU SN7444A, SN74LS42
4-LINE TO 10-LINE DECODERS (1-OF-10)

schematics of inputs and outputs

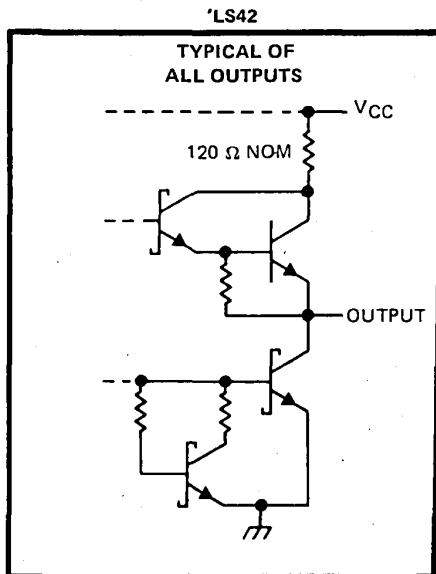
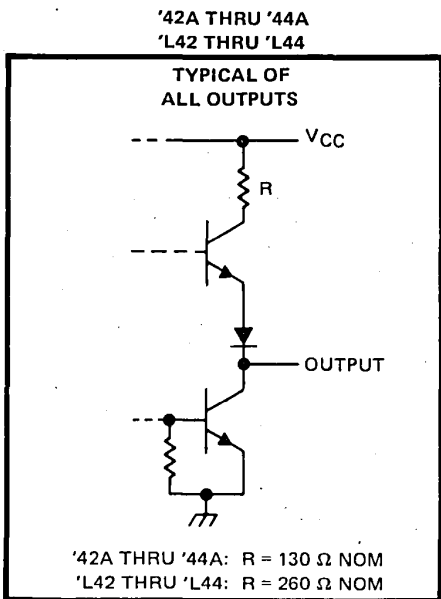
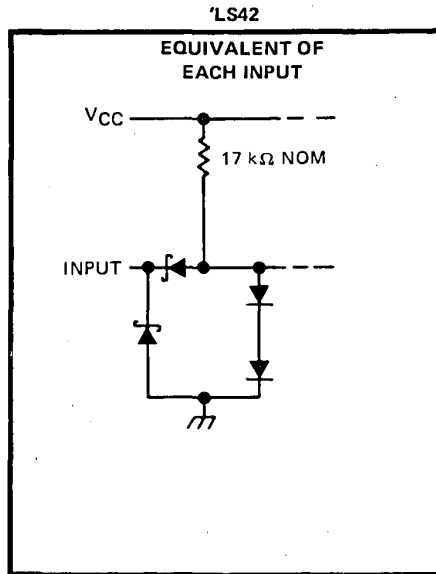
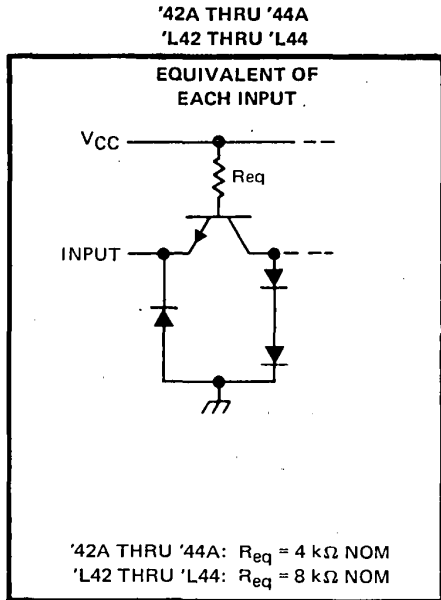

3

TTL DEVICES

**TYPES SN5442A THRU SN5444A, SN54L42 THRU SN54L44,
SN54LS42, SN7442A THRU SN7444A, SN74LS42
4-LINE TO 10-LINE DECODERS (1-OF-10)**

FUNCTION TABLE

NO.	'42A, 'L42, 'LS42 BCD INPUT				'43A, 'L43 EXCESS-3-INPUT				'44A, 'L44 GRAY INPUT				ALL TYPES DECIMAL OUTPUT										
	D	C	B	A	D	C	B	A	D	C	B	A	0	1	2	3	4	5	6	7	8	9	
0	L	L	L	L	L	L	H	H	L	L	H	L	L	H	H	H	H	H	H	H	H	H	H
1	L	L	L	H	L	H	L	L	L	H	H	L	H	L	H	H	H	H	H	H	H	H	H
2	L	L	H	L	L	H	L	H	L	H	H	H	H	H	L	H	H	H	H	H	H	H	H
3	L	L	H	H	L	H	H	L	L	H	L	H	H	H	H	L	H	H	H	H	H	H	H
4	L	H	L	L	L	H	H	H	L	H	L	L	H	H	H	H	L	H	H	H	H	H	H
5	L	H	L	H	H	L	L	L	L	H	H	L	L	H	H	H	H	L	H	H	H	H	H
6	L	H	H	L	H	L	L	H	H	H	L	H	H	H	H	H	H	H	L	H	H	H	H
7	L	H	H	H	H	L	H	L	H	H	H	H	H	H	H	H	H	H	H	L	H	H	H
8	H	L	L	L	H	L	H	H	H	H	H	L	H	H	H	H	H	H	H	H	L	H	H
9	H	L	L	H	H	H	L	L	L	H	L	H	L	H	H	H	H	H	H	H	H	H	L
INVALID	H	L	H	L	H	H	L	H	H	L	H	H	H	H	H	H	H	H	H	H	H	H	H
	H	L	H	H	H	H	H	L	H	L	L	H	H	H	H	H	H	H	H	H	H	H	H
	H	H	L	L	H	H	H	H	H	L	L	L	H	H	H	H	H	H	H	H	H	H	H
	H	H	H	L	L	L	L	H	L	L	L	H	H	H	H	H	H	H	H	H	H	H	H
	H	H	H	H	L	L	H	L	L	L	H	H	H	H	H	H	H	H	H	H	H	H	H

H = high level, L = low level

absolute maximum ratings over operating free-air temperature range (unless otherwise noted)

Supply voltage, V_{CC} (see Note 1)	7 V
Input voltage: '42A, '43A, '44A	5.5 V
'L42, 'L43, 'L44	5.5 V
'LS42	7 V
Operating free-air temperature: SN54'	-55°C to 125°C
SN74'	0°C to 70°C
Storage temperature range	-65°C to 150°C

NOTE 1: Voltage values are with respect to network ground terminal.

3

TTL DEVICES

**TYPES SN5442A, SN5443A, SN5444A, SN7442A, SN7443A, SN7444A
4-LINE TO 10-LINE DECODERS (1-OF-10)**

recommended operating conditions

	SN5442A SN5443A SN5444A			SN7442A SN7443A SN7444A			UNIT
	MIN	NOM	MAX	MIN	NOM	MAX	
Supply voltage, V_{CC}	4.5	5	5.5	4.75	5	5.25	V
High-level output current, I_{OH}			-800			-800	μ A
Low-level output current, I_{OL}			16			16	mA
Operating free-air temperature, T_A	-55		125	0		70	$^{\circ}$ C

electrical characteristics over recommended operating free-air temperature range (unless otherwise noted)

PARAMETER	TEST CONDITIONS [†]	SN5442A SN5443A SN5444A			SN7442A SN7443A SN7444A			UNIT
		MIN	TYP [‡]	MAX	MIN	TYP [‡]	MAX	
V_{IH} High-level input voltage		2			2			V
V_{IL} Low-level input voltage				0.8			0.8	V
V_{IK} Input clamp voltage	$V_{CC} = \text{MIN}, I_I = -12 \text{ mA}$			-1.5			-1.5	V
V_{OH} High-level output voltage	$V_{CC} = \text{MIN}, V_{IH} = 2 \text{ V},$ $V_{IL} = 0.8 \text{ V}, I_{OH} = -800 \mu\text{A}$	2.4	3.4		2.4	3.4		V
V_{OL} Low-level output voltage	$V_{CC} = \text{MIN}, V_{IH} = 2 \text{ V},$ $V_{IL} = 0.8 \text{ V}, I_{OL} = 16 \text{ mA}$		0.2	0.4		0.2	0.4	V
I_I Input current at maximum input voltage	$V_{CC} = \text{MAX}, V_I = 5.5 \text{ V}$			1			1	mA
I_{IH} High-level input current	$V_{CC} = \text{MAX}, V_I = 2.4 \text{ V}$			40			40	μ A
I_{IL} Low level input current	$V_{CC} = \text{MAX}, V_I = 0.4 \text{ V}$			-1.6			-1.6	mA
I_{OS} Short-circuit output current [§]	$V_{CC} = \text{MAX}$	-20		-55	-18		-55	mA
I_{CC} Supply current	$V_{CC} = \text{MAX},$ See Note 2		28	41		28	56	mA

[†] For conditions shown as MIN or MAX, use the appropriate values specified under recommended operating conditions.

[‡] All typical values are at $V_{CC} = 5 \text{ V}, T_A = 25^{\circ}\text{C}$.

[§] Not more than one output should be shorted at a time.

NOTE 2: I_{CC} is measured with all outputs open and all inputs grounded.

switching characteristics, $V_{CC} = 5 \text{ V}, T_A = 25^{\circ}\text{C}$

PARAMETER	TEST CONDITIONS	MIN	TYP	MAX	UNIT	
t_{PHL} Propagation delay time, high-to-low-level output from A, B, C, or D through 2 levels of logic	$C_L = 15 \text{ pF},$ $R_L = 400 \Omega,$ See Note 3		14	25	ns	
t_{PHL} Propagation delay time, high-to-low-level output from A, B, C, or D through 3 levels of logic			17	30	ns	
t_{PLH} Propagation delay time, low-to-high-level output from A, B, C, and D through 2 levels of logic				10	25	ns
t_{PLH} Propagation delay time, low-to-high-level output from A, B, C, and D through 3 levels of logic				17	30	ns

NOTE 3: See General Information Section for load circuits and voltage waveforms.

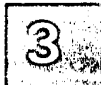

TTL DEVICES

TYPES SN54L42, SN54L43, SN54L44
4-LINE TO 10-LINE DECODERS (1-OF-10)

recommended operating conditions

	SN54L42 SN54L43 SN54L44			UNIT
	MIN	NOM	MAX	
V _{CC} Supply voltage	4.5	5	5.5	V
V _{IH} High-level input voltage	2			V
V _{IL} Low-level input voltage			0.8	V
I _{OH} High-level output current			-0.4	mA
I _{OL} Low-level output current			8	mA
T _A Operating free-air temperature	-55		125	°C

electrical characteristics over recommended operating free-air temperature range (unless otherwise noted)

PARAMETER	TEST CONDITIONS†	MIN	TYP	MAX	UNIT
V _{IK}	V _{CC} = MIN, I _I = -12 mA			-1.5	V
V _{OH}	V _{CC} = MIN, V _{IH} = 2 V, V _{IL} = 0.8 V, I _{OH} = -400 μA	2.4	3.4		V
V _{OL}	V _{CC} = MIN, V _{IH} = 2 V, V _{IL} = 0.8 V, I _{OL} = 8 mA		0.2	0.4	V
I _I	V _{CC} = MAX, V _I = 5.5 V			1	mA
I _{IH}	V _{CC} = MAX, V _I = 2.4 V			20	μA
I _{IL}	V _{CC} = MAX, V _I = 0.4 V			-0.8	mA
I _{OS} §	V _{CC} = MAX	-9		-28	mA
I _{CC}	V _{CC} = MAX, See Note 2		14	22	mA

† For conditions shown as MIN or MAX, use the appropriate values specified under recommended operating conditions.

All typical values are at V_{CC} = 5 V, T_A = 25°C.

§ Not more than one output should be shorted at a time.

NOTE 2: I_{CC} is measured with all outputs open and inputs grounded.

switching characteristics, V_{CC} = 5 V, T_A = 25°C

PARAMETER	TEST CONDITIONS	MIN	TYP	MAX	UNIT	
t _{PHL} Propagation delay time, high-to-low-level output from A, B, C, or D through 2 levels of logic	C _L = 15 pF, R _L = 800 Ω, See Note 3	10	44	60	ns	
t _{PHL} Propagation delay time, high-to-low-level output from A, B, C, or D through 3 levels of logic				46	70	ns
t _{PLH} Propagation delay time, low-to-high-level output from A, B, C, and D through 2 levels of logic			10	34	50	ns
t _{PLH} Propagation delay time, low-to-high-level output from A, B, C, and D through 3 levels of logic				52	70	ns

NOTE 3: See General Information Section for load circuits and voltage waveforms.

3

TTL DEVICES

TYPES SN54LS42, SN74LS42
4-LINE TO 10-LINE DECODERS (1-OF-10)

recommended operating conditions

	SN54LS42			SN74LS42			UNIT
	MIN	NOM	MAX	MIN	NOM	MAX	
Supply voltage, V_{CC}	4.5	5	5.5	4.75	5	5.25	V
High-level output current, I_{OH}			-400			-400	μ A
Low-level output current, I_{OL}			4			8	mA
Operating free-air temperature, T_A	-55		125	0		70	$^{\circ}$ C

electrical characteristics over recommended operating free-air temperature range (unless otherwise noted)

PARAMETER	TEST CONDITIONS [†]	SN54LS42		SN74LS42		UNIT		
		MIN	TYP [‡]	MAX	MIN		TYP [‡]	MAX
V_{IH} High-level input voltage		2			2	V		
V_{IL} Low-level input voltage				0.7		0.8	V	
V_{IK} Input clamp voltage	$V_{CC} = \text{MIN}, I_I = -18 \text{ mA}$			-1.5		-1.5	V	
V_{OH} High-level output voltage	$V_{CC} = \text{MIN}, V_{IH} = 2 \text{ V}, V_{IL} = V_{IL \text{ max}}, I_{OH} = -400 \mu\text{A}$	2.5	3.5		2.7	3.5	V	
V_{OL} Low-level output voltage	$V_{CC} = \text{MIN}, V_{IH} = 2 \text{ V}, V_{IL} = V_{IL \text{ max}}$						V	
				$I_{OL} = 4 \text{ mA}$	0.25	0.4		
				$I_{OL} = 8 \text{ mA}$		0.35	0.5	
I_I Input current at maximum input voltage	$V_{CC} = \text{MAX}, V_I = 7 \text{ V}$			0.1		0.1	mA	
I_{IH} High-level input current	$V_{CC} = \text{MAX}, V_I = 2.7 \text{ V}$			20		20	μ A	
I_{IL} Low-level input current	$V_{CC} = \text{MAX}, V_I = 0.4 \text{ V}$			-0.4		-0.4	mA	
I_{OS} Short-circuit output current [§]	$V_{CC} = \text{MAX}$	-20		-100	-20	-100	mA	
I_{CC} Supply current	$V_{CC} = \text{MAX},$ See Note 2		7	13		7	13	mA

[†]For conditions shown as MIN or MAX, use the appropriate value specified under recommended operating conditions.

[‡]All typical values are at $V_{CC} = 5 \text{ V}, T_A = 25^{\circ}\text{C}$.

[§]Not more than one output should be shorted at a time, and duration of the short-circuit should not exceed one second.

NOTE 2. I_{CC} is measured with all outputs open and inputs grounded.

switching characteristics, $V_{CC} = 5 \text{ V}, T_A = 25^{\circ}\text{C}$

PARAMETER	TEST CONDITIONS	MIN	TYP	MAX	UNIT
t_{PHL} Propagation delay time, high-to-low-level output from A, B, C, or D through 2 levels of logic	$C_L = 15 \text{ pF}, R_L = 2 \text{ k}\Omega,$ See Note 3		15	25	ns
t_{PHL} Propagation delay time, high-to-low-level output from A, B, C, or D through 3 levels of logic			20	30	ns
t_{PLH} Propagation delay time, low-to-high-level output from A, B, C, and D through 2 levels of logic			15	25	ns
t_{PLH} Propagation delay time, low-to-high-level output from A, B, C, and D through 3 levels of logic			20	30	ns

Note 3: See General Information Section for load circuits and voltage waveforms.



TTL DEVICES