

TYPES SN54246 THRU SN54249, SN54LS247 THRU SN54LS249,
SN74246 THRU SN74249, SN74LS247 THRU SN74LS249
BCD-TO-SEVEN-SEGMENT DECODERS/DRIVERS

MARCH 1974—REVISED DECEMBER 1983

'246, '247, 'LS247
feature

'248, 'LS248
feature

'249, 'LS249
feature

- Open-Collector Outputs Drive Indicators Directly
- Lamp-Test Provision
- Leading/Trailing Zero Suppression
- Internal Pull-Ups Eliminate Need for External Resistors
- Lamp-Test Provision
- Leading/Trailing Zero Suppression
- Open-Collector Outputs
- Lamp-Test Provision
- Leading/Trailing Zero Suppression

• All Circuit Types Feature Lamp Intensity Modulation Capability

TYPE	DRIVER OUTPUTS				TYPICAL POWER DISSIPATION	PACKAGES
	ACTIVE LEVEL	OUTPUT CONFIGURATION	SINK CURRENT	MAX VOLTAGE		
SN54246	low	open-collector	40 mA	30 V	320 mW	J, W
SN54247	low	open-collector	40 mA	15 V	320 mW	J, W
SN54248	high	2-k Ω pull-up	6.4 mA	5.5 V	265 mW	J, W
SN54249	high	open-collector	10 mA	5.5 V	265 mW	J, W
SN54LS247	low	open-collector	12 mA	15 V	35 mW	J, W
SN54LS248	high	2-k Ω pull-up	2 mA	5.5 V	125 mW	J, W
SN54LS249	high	open-collector	4 mA	5.5 V	40 mW	J, W
SN74246	low	open-collector	40 mA	30 V	320 mW	J, N
SN74247	low	open-collector	40 mA	15 V	320 mW	J, N
SN74248	high	2-k Ω pull-up	6.4 mA	5.5 V	265 mW	J, N
SN74249	high	open-collector	10 mA	5.5 V	265 mW	J, N
SN74LS247	low	open-collector	24 mA	15 V	35 mW	J, N
SN74LS248	high	2-k Ω pull-up	6 mA	5.5 V	125 mW	J, N
SN74LS249	high	open-collector	8 mA	5.5 V	40 mW	J, N

SN54246 THRU SN54249
SN54LS247 THRU SN54LS249 ... J OR W PACKAGE
SN74246 THRU SN74249 ... J OR N PACKAGE
SN74LS247 THRU SN74LS249 ... D, J OR N PACKAGE

(TOP VIEW)

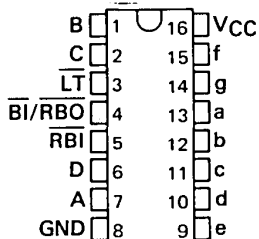

SN54LS247 THRU SN54LS249 ... FK PACKAGE
SN74LS247 THRU SN74LS249 ... FN PACKAGE

(TOP VIEW)

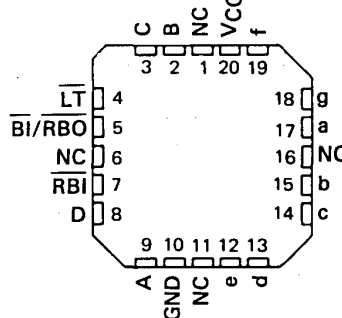

NC - No internal connection

description

The '246 through '248 are electrically and functionally identical to the SN5446A/SN7446A, SN5447A/SN7447A, and SN5448/SN7448, respectively, and have the same pin assignments as their equivalents. Also the 'LS247 and 'LS248 are electrically and functionally identical to the SN54LS47/SN74LS47 and SN54LS48/SN74LS48, respectively, and have the same pin assignments as their equivalents. They can be used interchangeably in present or future designs to offer designers a choice between two indicator fonts. The '249 and 'LS249 are 16-pin versions of the 14-pin SN5449 and SN54LS49/SN74LS49, respectively. Included in the '249 and 'LS249 circuits is the full functional capability for lamp test and ripple blanking, which is not available in the '49 and 'LS49 circuits. The '46A, '47A, '48, '49, 'LS47, 'LS48, and 'LS49 compose the \square and the \sqsubset without tails and the '246 through '249 and 'LS247, 'LS248, and 'LS249

PRODUCTION DATA

This document contains information current as of publication date. Products conform to specifications per the terms of Texas Instruments standard warranty. Production processing does not necessarily include testing of all parameters.

TEXAS
INSTRUMENTS

POST OFFICE BOX 225012 • DALLAS, TEXAS 75265

3-829



TTL DEVICES

**TYPES SN54246 THRU SN54249, SN54LS247 THRU SN54LS249,
SN74246 THRU SN74249, SN74LS247 THRU SN74LS249
BCD-TO-SEVEN-SEGMENT DECODERS/DRIVERS**

description (continued)

compose the 0 and the 9 with tails. Composition of all other characters, including display patterns for BCD inputs above nine, is identical. The '246, '247, and 'LS247 feature active-low outputs designed for driving indicators directly, and the '248, '249, 'LS248, and 'LS249 feature active-high outputs for driving lamp buffers. All of the circuits have full ripple-blanking input/output controls and a lamp test input. Segment identification and resultant displays are shown below. Display patterns for BCD input counts above 9 are unique symbols to authenticate input conditions.

All of these circuits incorporate automatic leading and/or trailing-edge zero-blanking control ($\overline{\text{RBI}}$ and $\overline{\text{RBO}}$). Lamp test (LT) of these types may be performed at any time when the BI/RBO node is at a high level. All types contain an overriding blanking input (BI) which can be used to control the lamp intensity by pulsing or to inhibit the outputs. Inputs and outputs are entirely compatible for use with TTL logic outputs.

Series 54 and Series 54LS devices are characterized for operation over the full military temperature range of -55°C to 125°C ; Series 74 and Series 74LS devices are characterized for operation from 0°C to 70°C .

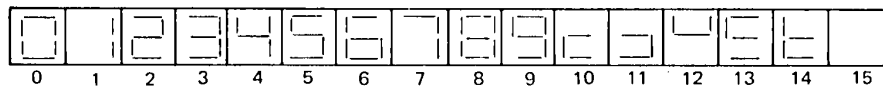
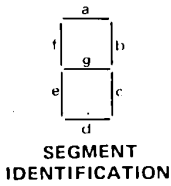

'246, '247, 'LS247
FUNCTION TABLE

DECIMAL OR FUNCTION	INPUTS						$\overline{\text{BI/RBO}}^{\dagger}$	OUTPUTS							NOTE
	LT	RBI	D	C	B	A		a	b	c	d	e	f	g	
0	H	H	L	L	L	L	H	ON	ON	ON	ON	ON	ON	OFF	1
1	H	X	L	L	L	H	H	OFF	ON	ON	OFF	OFF	OFF	OFF	
2	H	X	L	L	H	L	H	ON	ON	OFF	ON	ON	OFF	ON	
3	H	X	L	L	H	H	H	ON	ON	ON	ON	OFF	OFF	ON	
4	H	X	L	H	L	L	H	OFF	ON	ON	OFF	OFF	ON	ON	
5	H	X	L	H	L	H	H	ON	OFF	ON	ON	OFF	ON	ON	
6	H	X	L	H	H	L	H	ON	OFF	ON	ON	ON	ON	ON	
7	H	X	L	H	H	H	H	ON	ON	ON	OFF	OFF	OFF	OFF	
8	H	X	H	L	L	L	H	ON	ON	ON	ON	ON	ON	ON	
9	H	X	H	L	L	H	H	ON	ON	ON	ON	OFF	ON	ON	
10	H	X	H	L	H	L	H	OFF	OFF	OFF	ON	ON	OFF	ON	
11	H	X	H	L	H	H	H	OFF	OFF	ON	ON	OFF	OFF	ON	
12	H	X	H	H	L	L	H	OFF	ON	OFF	OFF	OFF	ON	ON	
13	H	X	H	H	L	H	H	ON	OFF	OFF	ON	OFF	ON	ON	
14	H	X	H	H	H	L	H	OFF	OFF	OFF	ON	ON	ON	ON	
15	H	X	H	H	H	H	H	OFF	OFF	OFF	OFF	OFF	OFF	OFF	
$\overline{\text{BI}}$	X	X	X	X	X	X	L	OFF	OFF	OFF	OFF	OFF	OFF	OFF	2
$\overline{\text{RBI}}$	H	L	L	L	L	L	L	OFF	OFF	OFF	OFF	OFF	OFF	OFF	3
$\overline{\text{LT}}$	L	X	X	X	X	X	H	ON	ON	ON	ON	ON	ON	ON	4

H = high level, L = low level, X = irrelevant

- NOTES: 1. The blanking input ($\overline{\text{BI}}$) must be open or held at a high logic level when output functions 0 through 15 are desired. The ripple-blanking input ($\overline{\text{RBI}}$) must be open or high if blanking of a decimal zero is not desired.
2. When a low logic level is applied directly to the blanking input ($\overline{\text{BI}}$), all segment outputs are off regardless of the level of any other input.
3. When ripple-blanking input ($\overline{\text{RBI}}$) and inputs A, B, C, and D are at a low level with the lamp test input high, all segment outputs go off and the ripple-blanking output ($\overline{\text{RBO}}$) goes to a low level (response condition).
4. When the blanking input/ripple-blanking output ($\overline{\text{BI/RBO}}$) is open or held high and a low is applied to the lamp-test input, all segment outputs are on.

$^{\dagger}\overline{\text{BI/RBO}}$ is wire-AND logic serving as blanking input ($\overline{\text{BI}}$) and/or ripple-blanking output ($\overline{\text{RBO}}$).

TYPES SN54248, SN54249, SN54LS248, SN54LS249,
SN74248, SN74249, SN74LS248, SN74LS249
BCD-TO-SEVEN-SEGMENT DECODERS/DRIVERS

'248, '249, 'LS248, 'LS249

FUNCTION TABLE

DECIMAL OR FUNCTION	INPUTS						$\overline{\text{BI/RBO}}^\dagger$	OUTPUTS							NOTE
	$\overline{\text{LT}}$	$\overline{\text{RBI}}$	D	C	B	A		a	b	c	d	e	f	g	
0	H	H	L	L	L	L	H	H	H	H	H	H	L	1	
1	H	X	L	L	L	H	H	L	H	H	L	L	L	1	
2	H	X	L	L	H	L	H	H	H	L	H	H	L		
3	H	X	L	L	H	H	H	H	H	H	L	L	H		
4	H	X	L	H	L	L	H	L	H	H	L	L	H		
5	H	X	L	H	L	H	H	H	L	H	H	L	H		
6	H	X	L	H	H	L	H	H	L	H	H	H	H		
7	H	X	L	H	H	H	H	H	H	H	L	L	L	1	
8	H	X	H	L	L	L	H	H	H	H	H	H	H		
9	H	X	H	L	L	H	H	H	H	H	L	H	H		
10	H	X	H	L	H	L	H	L	L	L	H	H	L		
11	H	X	H	L	H	H	H	L	L	H	H	L	H		
12	H	X	H	H	L	L	H	L	H	L	L	L	H		
13	H	X	H	H	L	H	H	H	L	L	H	L	H		
14	H	X	H	H	H	L	H	L	L	L	H	H	H		
15	H	X	H	H	H	H	H	L	L	L	L	L	L		
$\overline{\text{BI}}$	X	X	X	X	X	X	L	L	L	L	L	L	L	2	
$\overline{\text{RBI}}$	H	L	L	L	L	L	L	L	L	L	L	L	L	3	
$\overline{\text{LT}}$	L	X	X	X	X	X	H	H	H	H	H	H	H	4	

H = high level, L = low level, X = irrelevant

- NOTES: 1. The blanking input ($\overline{\text{BI}}$) must be open or held at a high logic level when output functions 0 through 15 are desired. The ripple-blanking input ($\overline{\text{RBI}}$) must be open or high if blanking of a decimal zero is not desired.
2. When a low logic level is applied directly to the blanking input ($\overline{\text{BI}}$), all segment outputs are low regardless of the level of any other input.
3. When ripple-blanking input ($\overline{\text{RBI}}$) and inputs A, B, C, and D are at a low level with the lamp test input high, all segment outputs go low and the ripple-blanking output ($\overline{\text{RBO}}$) goes to a low level (response condition).
4. When the blanking input/ripple-blanking output ($\overline{\text{BI/RBO}}$) is open or held high and a low is applied to the lamp-test input, all segment outputs are high.

$^\dagger \overline{\text{BI/RBO}}$ is wire-AND logic serving as blanking input ($\overline{\text{BI}}$) and/or ripple-blanking output ($\overline{\text{RBO}}$).



TTL DEVICES

TYPES SN54246, SN54247, SN54LS247,
 SN74246, SN74247, SN74LS247
 BCD-TO-SEVEN-SEGMENT DECODERS/DRIVERS

logic diagram

'246, '247, 'LS247

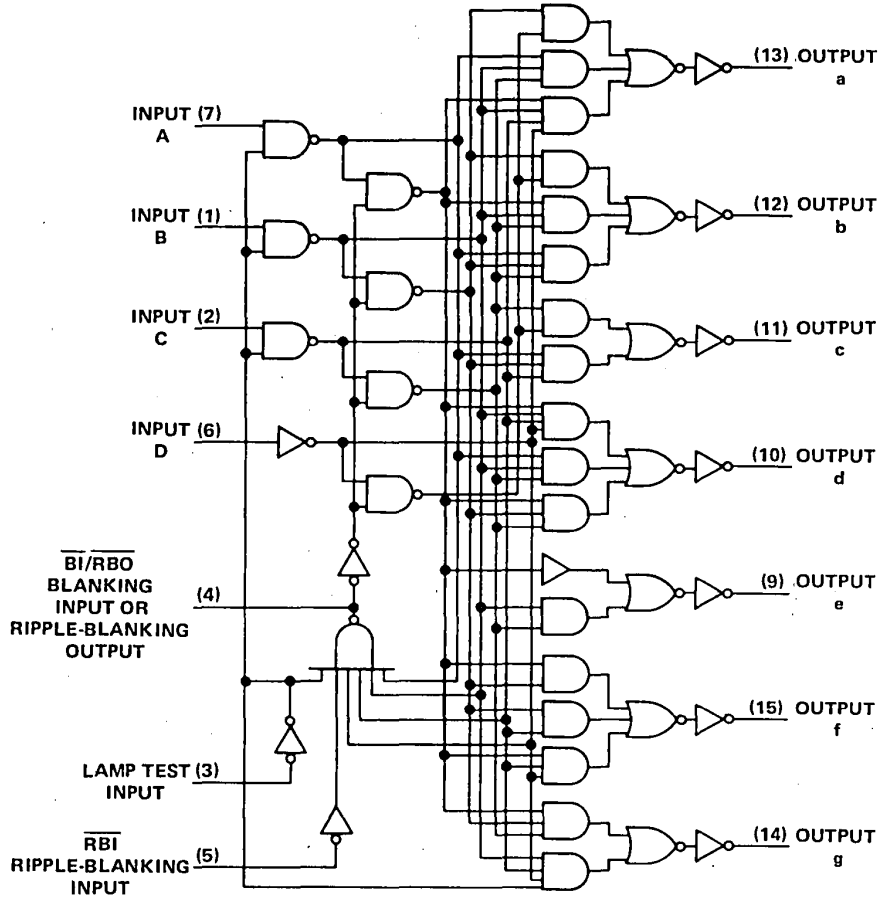

Pin numbers shown on logic notation are for D, J or N packages.

3
 TTL DEVICES

TYPES SN54248, SN54249, SN54LS248, SN54LS249,
 SN74248, SN74249, SN74LS248, SN74LS249
 BCD-TO-SEVEN-SEGMENT DECODERS/DRIVERS

logic diagrams

'248, '249, 'LS248, 'LS249

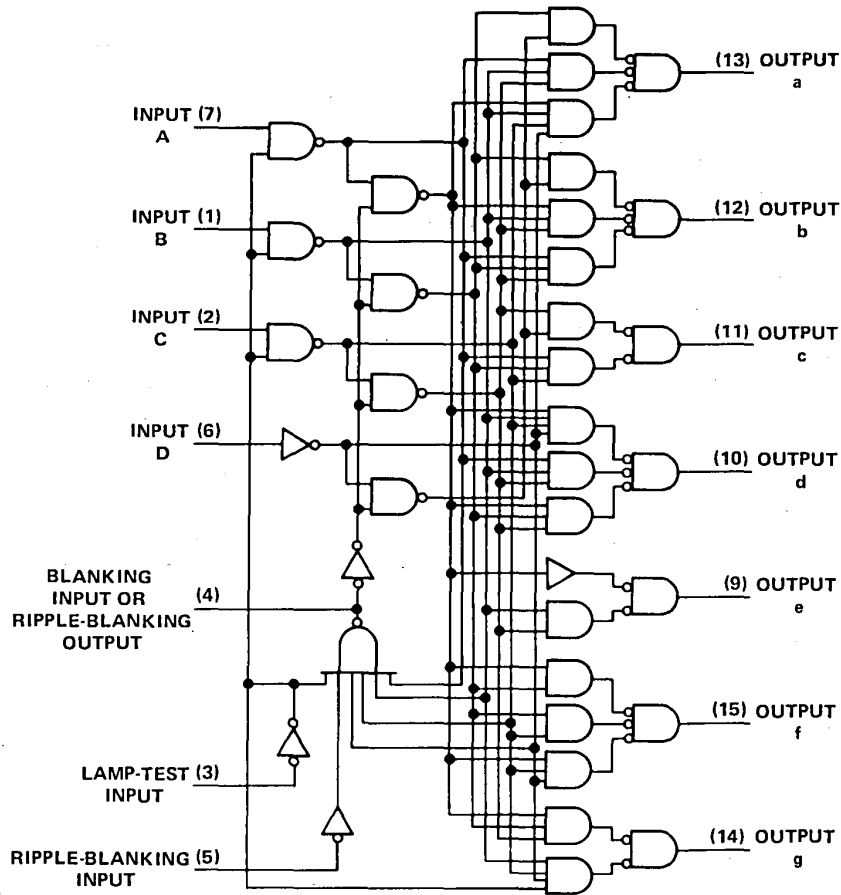

Pin numbers shown on logic notation are for D, J or N packages.

3

TTL DEVICES

TYPES SN54246 THRU SN54249, SN74246 THRU SN74249 BCD-TO-SEVEN-SEGMENT DECODERS/DRIVERS

schematics of inputs and outputs

'246, '247, '248, '249

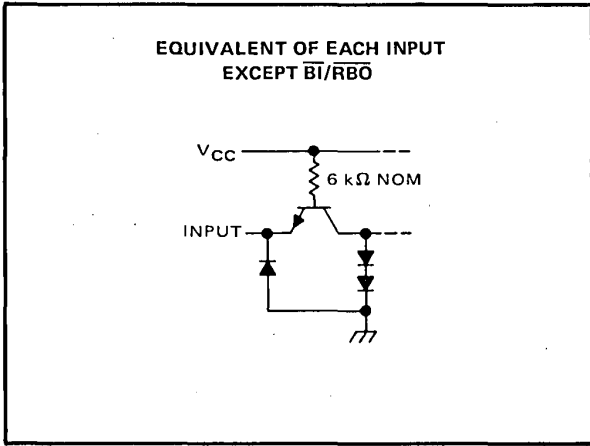

'246, '247, '248, '249

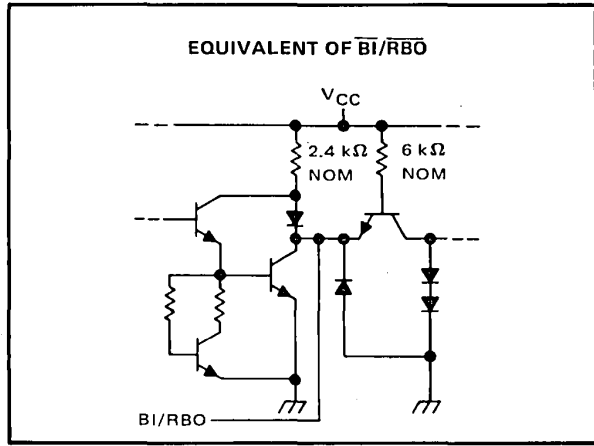

'246, '247

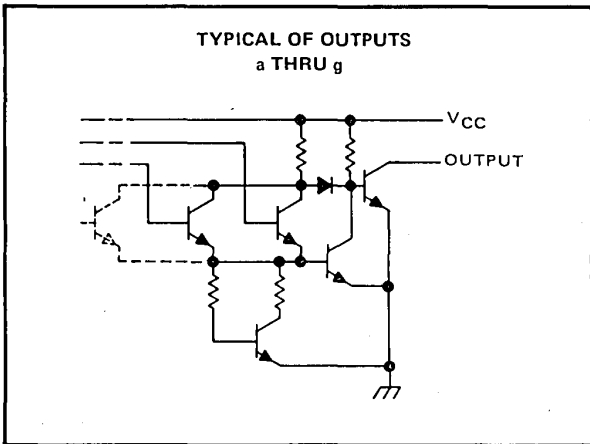

'248

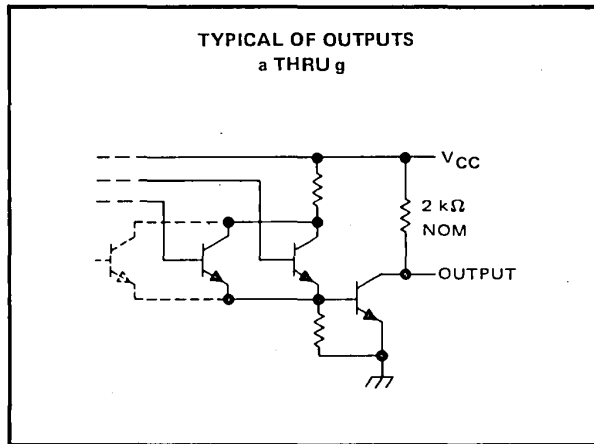

'249

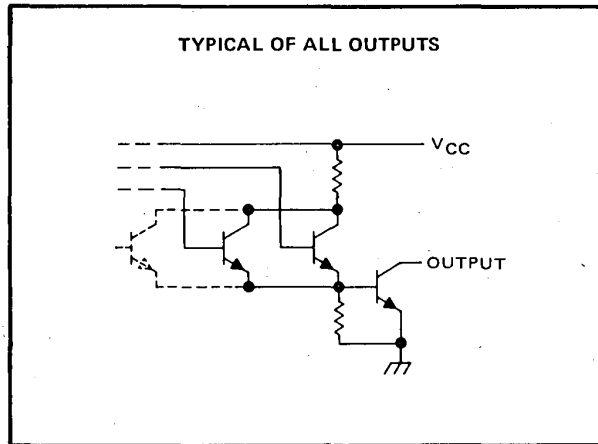

3

TTL DEVICES

TYPES SN54LS247 THRU SN54LS249, SN74LS247 THRU SN74LS249
BCD-TO-SEVEN-SEGMENT DECODERS/DRIVERS

schematics of inputs and outputs

'LS247, 'LS248, 'LS249

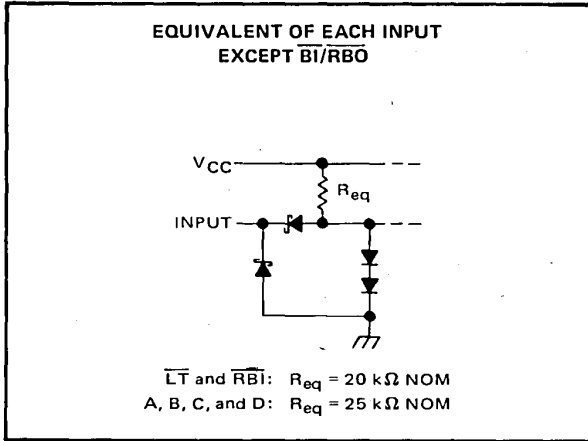

'LS247, 'LS248, 'LS249

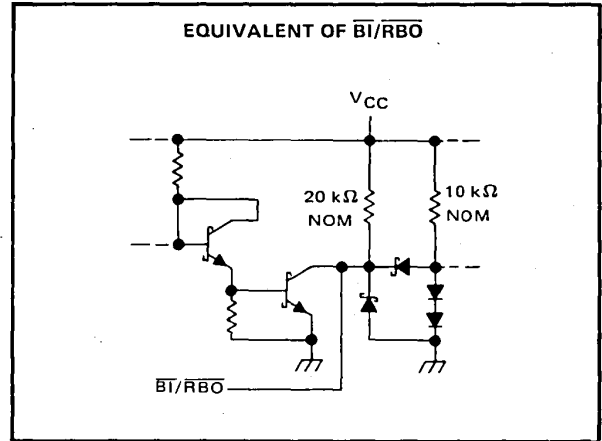

'LS247

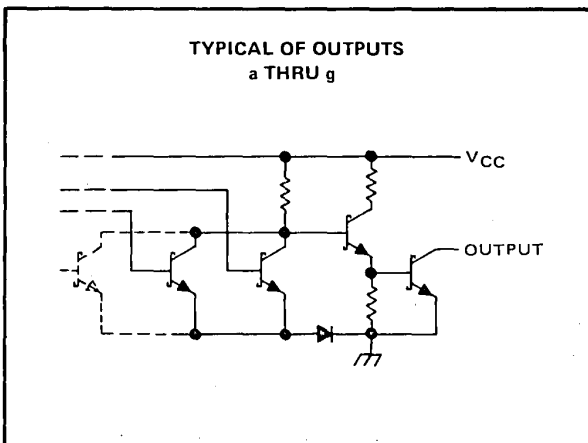

'LS248

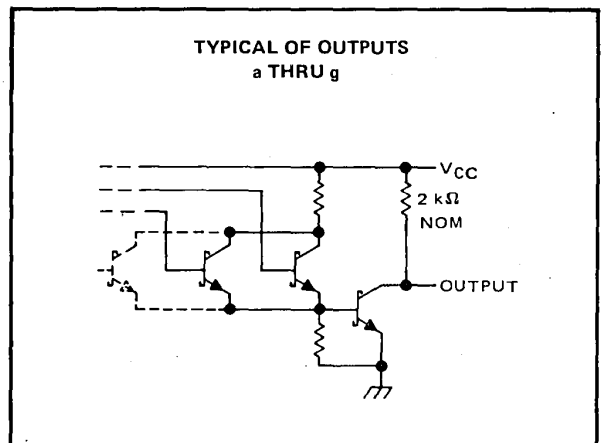

'LS249

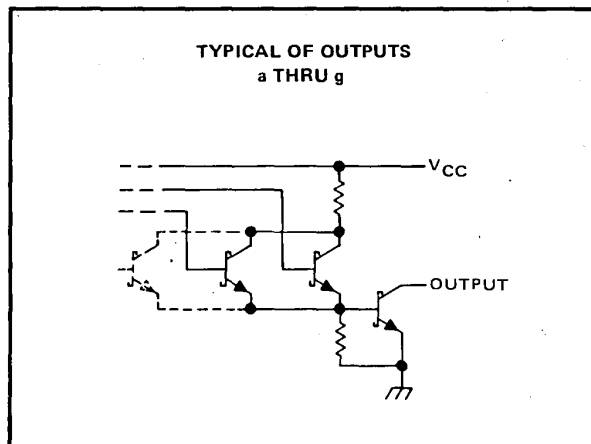

TYES SN54246, SN54247, SN74246, SN74247 BCD-TO-SEVEN-SEGMENT DECODERS/DRIVERS

absolute maximum ratings over operating free-air temperature range (unless otherwise noted)

Supply voltage, V_{CC} (see Note 1)	7 V
Input voltage	5.5 V
Current forced into any output in the off state	1 mA
Operating free-air temperature range: SN54246, SN54247	-55°C to 125°C
SN74246, SN74247	0°C to 70°C
Storage temperature range	-65°C to 150°C

NOTE 1: Voltage values are with respect to network ground terminal.

recommended operating conditions

	SN54246			SN54247			SN74246			SN74247			UNIT			
	MIN	NOM	MAX	MIN	NOM	MAX	MIN	NOM	MAX	MIN	NOM	MAX				
Supply voltage, V_{CC}	4.5	5	5.5	4.5	5	5.5	4.75	5	5.25	4.75	5	5.25	V			
Off-state output voltage, $V_{O(off)}$	a thru g			30			15			30			15		V	
On-state output current, $I_{O(on)}$	a thru g			40			40			40			40		mA	
High-level output current, I_{OH}	$\overline{BI}/\overline{RBO}$			-200			-200			-200			-200		μ A	
Low-level output current, I_{OL}	$\overline{BI}/\overline{RBO}$			8			8			8			8		mA	
Operating free-air temperature, T_A	-55			125			-55			125			0		70	°C

electrical characteristics over recommended operating free-air temperature range (unless otherwise noted)

PARAMETER		TEST CONDITIONS†	MIN	TYP‡	MAX	UNIT
V_{IH}	High-level input voltage		2			V
V_{IL}	Low-level input voltage				0.8	V
V_{IK}	Input clamp voltage	$V_{CC} = \text{MIN}, I_I = -12 \text{ mA}$			1.5	V
V_{OH}	High-level output voltage	$\overline{BI}/\overline{RBO}$ $V_{CC} = \text{MIN}, V_{IH} = 2 \text{ V},$ $V_{IL} = 0.8 \text{ V}, I_{OH} = -200 \mu\text{A}$	2.4	3.7		V
V_{OL}	Low-level output voltage	$\overline{BI}/\overline{RBO}$ $V_{CC} = \text{MIN}, V_{IH} = 2 \text{ V},$ $V_{IL} = 0.8 \text{ V}, I_{OL} = 8 \text{ mA}$	0.27	0.4		V
$I_{O(off)}$	Off-state output current	a thru g $V_{CC} = \text{MAX}, V_{IH} = 2 \text{ V},$ $V_{IL} = 0.8 \text{ V}, V_{O(off)} = \text{MAX}$			250	μ A
$V_{O(on)}$	On-state output voltage	a thru g $V_{CC} = \text{MIN}, V_{IH} = 2 \text{ V},$ $V_{IL} = 0.8 \text{ V}, I_{O(on)} = 40 \text{ mA}$	0.3	0.4		V
I_I	Input current at maximum input voltage	Any input except $\overline{BI}/\overline{RBO}$ $V_{CC} = \text{MAX}, V_I = 5.5 \text{ V}$			1	mA
I_{IH}	High-level input current	Any input except $\overline{BI}/\overline{RBO}$ $V_{CC} = \text{MAX}, V_I = 2.4 \text{ V}$			40	μ A
I_{IL}	Low-level input current	Any input except $\overline{BI}/\overline{RBO}$ $V_{CC} = \text{MAX}, V_I = 0.4 \text{ V}$			-1.6	mA
		$\overline{BI}/\overline{RBO}$			-4	
I_{OS}	Short-circuit output current	$\overline{BI}/\overline{RBO}$ $V_{CC} = \text{MAX}$			-4	mA
I_{CC}	Supply current	$V_{CC} = \text{MAX},$ See Note 2	64	103		mA

†For conditions shown as MIN or MAX, use the appropriate value specified under recommended operating conditions.

‡All typical values are at $V_{CC} = 5 \text{ V}, T_A = 25^\circ\text{C}$.

NOTE 2: I_{CC} is measured with all outputs open and all inputs at 4.5 V.

switching characteristics, $V_{CC} = 5 \text{ V}, T_A = 25^\circ\text{C}$

PARAMETER		TEST CONDITIONS	MIN	TYP	MAX	UNIT
t_{off}	Turn-off time from A input	$C_L = 15 \text{ pF}, R_L = 120 \Omega,$ See Note 3			100	ns
t_{on}	Turn-on time from A input				100	
t_{off}	Turn-off time from \overline{RBI} input				100	ns
t_{on}	Turn-on time from \overline{RBI} input				100	

NOTE 3: See General Information Section for load circuits and voltage waveforms.

3

TTL DEVICES

TYPES SN54LS247, SN74LS247 BCD-TO-SEVEN-SEGMENT DECODERS/DRIVERS

absolute maximum ratings over operating free-air temperature range (unless otherwise noted)

Supply voltage, V_{CC} (see Note 1)	7 V
Input voltage	7 V
Peak output current ($t_w \leq 1$ ms, duty cycle $\leq 10\%$)	200 mA
Current forced into any output in the off state	1 mA
Operating free-air temperature range: SN54LS247	-55°C to 125°C
SN74LS247	0°C to 70°C
Storage temperature range	-65°C to 150°C

NOTE 1: Voltage values are with respect to network ground terminal.

recommended operating conditions

	SN54LS247			SN74LS247			UNIT
	MIN	NOM	MAX	MIN	NOM	MAX	
Supply voltage, V_{CC}	4.5	5	5.5	4.75	5	5.25	V
Off-state output voltage, $V_{O(off)}$	a thru g			15			V
On-state output current, $I_{O(on)}$	a thru g			12			mA
High-level output current, I_{OH}	BI/RBO			-50			μA
Low-level output current, I_{OL}	BI/RBO			1.6			mA
Operating free-air temperature, T_A	-55		125	0		70	$^\circ\text{C}$

electrical characteristics over recommended operating free-air temperature range (unless otherwise noted)

PARAMETER	TEST CONDITIONS†	SN54LS247			SN74LS247			UNIT	
		MIN	TYP‡	MAX	MIN	TYP‡	MAX		
V_{IH} High-level input voltage		2			2			V	
V_{IL} Low-level input voltage				0.7			0.8	V	
V_{IK} Input clamp voltage	$V_{CC} = \text{MIN}, I_I = -18$ mA			-1.5			-1.5	V	
V_{OH} High-level output voltage	$\overline{\text{BI}}/\overline{\text{RBO}}, V_{CC} = \text{MIN}, V_{IH} = 2$ V, $V_{IL} = V_{IL \text{ max}}, I_{OH} = -50$ μA	2.4	4.2		2.4	4.2		V	
V_{OL} Low-level output voltage	$\overline{\text{BI}}/\overline{\text{RBO}}, V_{CC} = \text{MIN}, V_{IH} = 2$ V, $V_{IL} = V_{IL \text{ max}}$			0.25	0.4		0.25	0.4	V
	$I_{OL} = 1.6$ mA						0.35	0.5	
	$I_{OL} = 3.2$ mA								
$I_{O(off)}$ Off-state output current	a thru g, $V_{CC} = \text{MAX}, V_{IH} = 2$ V, $V_{IL} = V_{IL \text{ max}}, V_{O(off)} = 15$ V			250			250	μA	
$V_{O(on)}$ On-state output voltage	a thru g, $V_{CC} = \text{MIN}, V_{IH} = 2$ V, $V_{IL} = V_{IL \text{ max}}$			0.25	0.4		0.25	0.4	V
	$I_{O(on)} = 12$ mA						0.35	0.5	
	$I_{O(on)} = 24$ mA								
I_I Input current at maximum input voltage	$V_{CC} = \text{MAX}, V_I = 7$ V			0.1			0.1	mA	
I_{IH} High-level input current	$V_{CC} = \text{MAX}, V_I = 2.7$ V			20			20	μA	
I_{IL} Low-level input current	Any input except $\overline{\text{BI}}/\overline{\text{RBO}}, V_{CC} = \text{MAX}, V_I = 0.4$ V			-0.4			-0.4	mA	
	$\overline{\text{BI}}/\overline{\text{RBO}}$			-1.2			-1.2		
I_{OS} Short-circuit output current	$\overline{\text{BI}}/\overline{\text{RBO}}, V_{CC} = \text{MAX}$	-0.3		-2	-0.3		-2	mA	
I_{CC} Supply current	$V_{CC} = \text{MAX},$ See Note 2	7	13		7	13		mA	

†For conditions shown as MIN or MAX, use the appropriate value specified under recommended operating conditions.

‡All typical values are at $V_{CC} = 5$ V, $T_A = 25^\circ\text{C}$.

NOTE 2: I_{CC} is measured with all outputs open and all inputs at 4.5 V.

switching characteristics, $V_{CC} = 5$ V, $T_A = 25^\circ\text{C}$

PARAMETER	TEST CONDITIONS	MIN	TYP	MAX	UNIT
t_{off} Turn-off time from A input	$C_L = 15$ pF, $R_L = 665$ Ω , See Note 3			100	ns
t_{on} Turn-on time from A input				100	
t_{off} Turn-off time from $\overline{\text{RBI}}$ input				100	ns
t_{on} Turn-on time from $\overline{\text{RBI}}$ input				100	

NOTE 3: See General Information Section for load circuits and voltage waveforms.



POST OFFICE BOX 225012 • DALLAS, TEXAS 75265

3-837

3
TTL DEVICES

TYPES SN54248, SN74248 BCD-TO-SEVEN-SEGMENT DECODERS/DRIVERS

absolute maximum ratings over operating free-air temperature range (unless otherwise noted)

Supply voltage, V_{CC} (see Note 1)	7 V
Input voltage	5.5 V
Operating free-air temperature range: SN54248	-55°C to 125°C
SN74248	0°C to 70°C
Storage temperature range	-65°C to 150°C

NOTE 1: Voltage values are with respect to network ground terminals.

recommended operating conditions

	SN54248			SN74248			UNIT
	MIN	NOM	MAX	MIN	NOM	MAX	
Supply voltage, V_{CC}	4.5	5	5.5	4.75	5	5.25	V
High-level output current, I_{OH}	a thru g		-400			-400	μ A
	$\overline{BI}/\overline{RBO}$		-200			-200	
Low-level output current, I_{OL}	a thru g		6.4			6.4	mA
	$\overline{BI}/\overline{RBO}$		8			8	
Operating free-air temperature, T_A	-55		125	0		70	°C

electrical characteristics over recommended operating free-air temperature range (unless otherwise noted)

PARAMETER		TEST CONDITIONS†	MIN	TYP‡	MAX	UNIT
V_{IH}	High-level input voltage		2			V
V_{IL}	Low-level input voltage				0.8	V
V_{IK}	Input clamp voltage	$V_{CC} = \text{MIN}, I_I = -12 \text{ mA}$			-1.5	V
V_{OH}	High-level output voltage	a thru g	$V_{CC} = \text{MIN}, V_{IH} = 2 \text{ V},$	2.4	4.2	V
		$\overline{BI}/\overline{RBO}$	$V_{IL} = 0.8 \text{ V}, I_{OH} = \text{MAX}$	2.4	3.7	
I_O	Output current	a thru g	$V_{CC} = \text{MIN}, V_O = 0.85 \text{ V},$	-1.3	-2	mA
			Input conditions as for V_{OH}			
V_{OL}	Low-level output voltage		$V_{CC} = \text{MIN}, V_{IH} = 2 \text{ V},$	0.27	0.4	V
			$V_{IL} = 0.8 \text{ V}, I_{OL} = \text{MAX}$			
I_I	Input current at maximum input voltage	Any input except $\overline{BI}/\overline{RBO}$	$V_{CC} = \text{MAX}, V_I = 5.5 \text{ V}$		1	mA
I_{IH}	High-level input current	Any input except $\overline{BI}/\overline{RBO}$	$V_{CC} = \text{MAX}, V_I = 2.4 \text{ V}$		40	
I_{IL}	Low-level input current	Any input except $\overline{BI}/\overline{RBO}$	$V_{CC} = \text{MAX}, V_I = 0.4 \text{ V}$		-1.6	mA
		$\overline{BI}/\overline{RBO}$			-4	
I_{OS}	Short-circuit output current	$\overline{BI}/\overline{RBO}$	$V_{CC} = \text{MAX}$		-4	mA
I_{CC}	Supply current		$V_{CC} = \text{MAX},$ See Note 2	53	90	

†For conditions shown as MIN or MAX, use the appropriate value specified under recommended operating conditions.

‡All typical values are at $V_{CC} = 5 \text{ V}, T_A = 25^\circ\text{C}$.

NOTE 2: I_{CC} is measured with all outputs open and all inputs at 4.5 V.

switching characteristics, $V_{CC} = 5 \text{ V}, T_A = 25^\circ\text{C}$

PARAMETER		TEST CONDITIONS	MIN	TYP	MAX	UNIT
t_{PHL}	Propagation delay time, high-to-low-level output from A input	$C_L = 15 \text{ pF}, R_L = 1 \text{ k}\Omega,$ See Note 3			100	ns
t_{PLH}	Propagation delay time, low-to-high-level output from A input				100	
t_{PHL}	Propagation delay time, high-to-low-level output from \overline{RBI} input				100	ns
t_{PLH}	Propagation delay time, low-to-high-level output from \overline{RBI} input				100	

NOTE 3: See General Information Section for load circuits and voltage waveforms.

TYPES SN54LS248, SN74LS248 BCD-TO-SEVEN-SEGMENT DECODERS/DRIVERS

absolute maximum ratings over operating free-air temperature range (unless otherwise noted)

Supply voltage, V_{CC} (see Note 1)	7 V
Input voltage	7 V
Operating free-air temperature range: SN54LS248	-55°C to 125°C
SN74LS248	0°C to 70°C
Storage temperature range	-65°C to 150°C

NOTE 1: Voltage values are with respect to network ground terminal.

recommended operating conditions

	SN54LS248			SN74LS248			UNIT
	MIN	NOM	MAX	MIN	NOM	MAX	
Supply voltage, V_{CC}	4.5	5	5.5	4.75	5	5.25	V
High-level output current, I_{OH}	a thru g		-100			-100	μ A
	$\overline{BI}/\overline{RBO}$		-50			-50	
Low-level output current, I_{OL}	a thru g		2			6	mA
	$\overline{BI}/\overline{RBO}$		1.6			3.2	
Operating free-air temperature, T_A	-55		125	0		70	°C

electrical characteristics over recommended operating free-air temperature range (unless otherwise noted)

PARAMETER	TEST CONDITIONS†	SN54LS248		SN74LS248		UNIT		
		MIN	TYP‡	MAX	MIN		TYP‡	MAX
V_{IH} High-level input voltage		2			2	V		
V_{IL} Low-level input voltage				0.7		0.8	V	
V_{IK} Input clamp voltage	$V_{CC} = \text{MIN}, I_I = -18 \text{ mA}$			-1.5		-1.5	V	
V_{OH} High-level output voltage	a thru g and $\overline{BI}/\overline{RBO}$ $V_{CC} = \text{MIN}, V_{IH} = 2 \text{ V},$ $V_{IL} = V_{IL \text{ max}}, I_{OH} = \text{MAX}$	2.4	4.2		2.4	4.2	V	
I_O Output current	a thru g $V_{CC} = \text{MIN}, V_O = 0.85 \text{ V},$ Input conditions as for V_{OH}	-1.3	-2		-1.3	-2	mA	
V_{OL} Low-level output voltage	a thru g $V_{CC} = \text{MIN},$ $V_{IH} = 2 \text{ V},$ $V_{IL} = V_{IL \text{ max}}$	$I_{OL} = 2 \text{ mA}$	0.25	0.4	0.25	0.4	V	
		$I_{OL} = 6 \text{ mA}$			0.35	0.5		
	$\overline{BI}/\overline{RBO}$ $V_{CC} = \text{MIN},$ $V_{IH} = 2 \text{ V},$ $V_{IL} = V_{IL \text{ max}}$	$I_{OL} = 1.6 \text{ mA}$	0.25	0.4	0.25	0.4	V	
		$I_{OL} = 3.2 \text{ mA}$			0.35	0.5		
I_I Input current at maximum input voltage	Any input except $\overline{BI}/\overline{RBO}$ $V_{CC} = \text{MAX}, V_I = 7 \text{ V}$			0.1		0.1	mA	
I_{IH} High-level input current	Any input except $\overline{BI}/\overline{RBO}$ $V_{CC} = \text{MAX}, V_I = 2.7 \text{ V}$			20		20	μ A	
I_{IL} Low-level input current	Any input except $\overline{BI}/\overline{RBO}$ $V_{CC} = \text{MAX}, V_I = 0.4 \text{ V}$			-0.4		-0.4	mA	
	$\overline{BI}/\overline{RBO}$			-1.2		-1.2		
I_{OS} Short-circuit output current	$\overline{BI}/\overline{RBO}$ $V_{CC} = \text{MAX}$	-0.3		-2	-0.3	-2	mA	
I_{CC} Supply current	$V_{CC} = \text{MAX},$ See Note 2		25	38		25	38	mA

†For conditions shown as MIN or MAX, use the appropriate value specified under recommended operating conditions.

‡All typical values are at $V_{CC} = 5 \text{ V}, T_A = 25^\circ \text{C}$.

NOTE 2: I_{CC} is measured with all outputs open and all inputs at 4.5 V.

switching characteristics, $V_{CC} = 5 \text{ V}, T_A = 25^\circ \text{C}$

PARAMETER	TEST CONDITIONS	MIN	TYP	MAX	UNIT
t_{PHL} Propagation delay time, high-to-low-level output from A input	$C_L = 15 \text{ pF}, R_L = 4 \text{ k}\Omega,$			100	ns
t_{PLH} Propagation delay time, low-to-high-level output from A input	See Note 3			100	
t_{PHL} Propagation delay time, high-to-low-level output from \overline{RBI} input	$C_L = 15 \text{ pF}, R_L = 6 \text{ k}\Omega,$			100	ns
t_{PLH} Propagation delay time, low-to-high-level output from \overline{RBI} input	See Note 3			100	

NOTE 3: See General Information Section for load circuits and voltage waveforms.

TYPES SN54249, SN74249 BCD-TO-SEVEN-SEGMENT DECODERS/DRIVERS

absolute maximum ratings over operating free-air temperature range (unless otherwise noted)

Supply voltage, V_{CC} (see Note 1)	7 V
Input voltage	5.5 V
Current forced into any output in the off state	1 mA
Operating free-air temperature range: SN54249	-55°C to 125°C
SN74249	0°C to 70°C
Storage temperature range	-65°C to 150°C

NOTE 1: Voltage values are with respect to network ground terminal.

recommended operating conditions

	SN54249			SN74249			UNIT
	MIN	NOM	MAX	MIN	NOM	MAX	
Supply voltage, V_{CC}	4.5	5	5.5	4.75	5	5.25	V
High-level output voltage, V_{OH}	5.5			5.5			V
High-level output current, I_{OH}	BI/RBO			-200			μ A
Low-level output current, I_{OL}	a thru g			10			mA
	BI/RBO			8			
Operating free-air temperature, T_A	-55		125	0		70	°C

electrical characteristics over recommended operating free-air temperature range (unless otherwise noted)

PARAMETER		TEST CONDITIONS†	MIN	TYP‡	MAX	UNIT
V_{IH}	High-level input voltage		2			V
V_{IL}	Low-level input voltage				0.8	V
V_{IK}	Input clamp voltage	$V_{CC} = \text{MIN}, I_I = -12 \text{ mA}$			-1.5	V
V_{OH}	High-level output voltage	BI/RBO $V_{CC} = \text{MIN}, V_{IH} = 2 \text{ V}, V_{IL} = 0.8 \text{ V}, I_{OH} = \text{MAX}$	2.4	3.7		V
I_{OH}	High-level output current	a thru g $V_{CC} = \text{MIN}, V_{IH} = 2 \text{ V}, V_{IL} = 0.8 \text{ V}, V_{OH} = 5.5 \text{ V}$			250	μ A
V_{OL}	Low-level output voltage	$V_{CC} = \text{MIN}, V_{IH} = 2 \text{ V}, V_{IL} = 0.8 \text{ V}, I_{OL} = \text{MAX}$	0.27	0.4		V
I_I	Input current at maximum input voltage	Any input except BI/RBO $V_{CC} = \text{MAX}, V_I = 5.5 \text{ V}$			1	mA
I_{IH}	High-level input current	Any input except BI/RBO $V_{CC} = \text{MAX}, V_I = 2.4 \text{ V}$			40	μ A
I_{IL}	Low-level input current	Any input except BI/RBO $V_{CC} = \text{MAX}, V_I = 0.4 \text{ V}$			-1.6	mA
		BI/RBO			-4	
I_{OS}	Short-circuit output current	BI/RBO $V_{CC} = \text{MAX}$			-4	mA
I_{CC}	Supply current	$V_{CC} = \text{MAX}, \text{ See Note 2}$	53	90		mA

†For conditions shown as MIN or MAX, use the appropriate value specified under recommended operating conditions.

‡All typical values are at $V_{CC} = 5 \text{ V}, T_A = 25^\circ\text{C}$.

NOTE 2: I_{CC} is measured with all outputs open and all inputs at 4.5 V.

switching characteristics, $V_{CC} = 5 \text{ V}, T_A = 25^\circ\text{C}$

PARAMETER	TEST CONDITIONS	MIN	TYP	MAX	UNIT
t_{PHL}	Propagation delay time, high-to-low-level output from A input			100	ns
t_{PLH}	Propagation delay time, low-to-high-level output from A input			100	
t_{PHL}	Propagation delay time, high-to-low-level output from RBI input	See Note 3		100	ns
t_{PLH}	Propagation delay time, low-to-high-level output from RBI input			100	

NOTE 3: See General Information Section for load circuits and voltage waveforms.

3

TTL DEVICES

TYPES SN54LS249, SN74LS249 BCD-TO-SEVEN-SEGMENT DECODERS/DRIVERS

absolute maximum ratings over operating free-air temperature range (unless otherwise noted)

Supply voltage, V_{CC} (see Note 1)	7 V
Input voltage	7 V
Current forced into any output in the offstate	1 mA
Operating free-air temperature range: SN54LS249	-55°C to 125°C
SN74LS249	0°C to 70°C
Storage temperature range	-65°C to 150°C

NOTE 1: Voltage values are with respect to network ground terminal.

recommended operating conditions

	SN54LS249			SN74LS249			UNIT	
	MIN	NOM	MAX	MIN	NOM	MAX		
Supply voltage, V_{CC}	4.5	5	5.5	4.75	5	5.25	V	
High-level output voltage, V_{OH}	a thru g			5.5			V	
High-level output current, I_{OH}	$\overline{BI}/\overline{RBO}$			-50			μA	
Low-level output current, I_{OL}	a thru g			4			8	
	$\overline{BI}/\overline{RBO}$			1.6			3.2	
Operating free-air temperature, T_A	-55			125			0 70	°C

electrical characteristics over recommended operating free-air temperature range (unless otherwise noted)

PARAMETER		TEST CONDITIONS†	SN54LS249		SN74LS249		UNIT
			MIN	TYP‡	MAX	MIN	
V_{IH}	High-level input voltage		2		2		V
V_{IL}	Low-level input voltage		0.7		0.8		V
V_{IK}	Input clamp voltage	$V_{CC} = \text{MIN}, I_I = -18 \text{ mA}$	-1.5		-1.5		V
V_{OH}	High-level output voltage	$\overline{BI}/\overline{RBO}$ $V_{CC} = \text{MIN}, V_{IH} = 2 \text{ V},$ $V_{IL} = V_{IL \text{ max}}, I_{OH} = -50 \mu A$	2.4	4.2	2.4	4.2	V
I_{OH}	High-level output current	a thru g $V_{CC} = \text{MIN}, V_{IH} = 2 \text{ V},$ $V_{IL} = V_{IL \text{ max}}, V_{OH} = 5.5 \text{ V}$	250		250		μA
V_{OL}	Low-level output voltage	$\overline{BI}/\overline{RBO}$	0.25	0.4	0.25	0.4	V
		$I_{OL} = 1.6 \text{ mA}$					
	a thru g	$V_{CC} = \text{MIN}, V_{IH} = 2 \text{ V},$ $V_{IL} = V_{IL \text{ max}}$	0.25	0.4	0.25	0.4	V
$I_{OL} = 3.2 \text{ mA}$							
I_I	Input current at maximum input voltage	Any input except $\overline{BI}/\overline{RBO}$ $V_{CC} = \text{MAX}, V_I = 7 \text{ V}$	0.1		0.1		mA
I_{IH}	High-level input current	Any input except $\overline{BI}/\overline{RBO}$ $V_{CC} = \text{MAX}, V_I = 2.7 \text{ V}$	20		20		μA
I_{IL}	Low-level input current	Any input except $\overline{BI}/\overline{RBO}$ $V_{CC} = \text{MAX}, V_I = 0.4 \text{ V}$	-0.4		-0.4		mA
		$\overline{BI}/\overline{RBO}$	-1.2		-1.2		
I_{OS}	Short-circuit output current	$\overline{BI}/\overline{RBO}$ $V_{CC} = \text{MAX}$	-0.3	-2	-0.3	-2	mA
I_{CC}	Supply current	$V_{CC} = \text{MAX},$ See Note 2	8	15	8	15	mA

†For conditions shown as MIN or MAX, use the appropriate value specified under recommended operating conditions.

‡All typical values are at $V_{CC} = 5 \text{ V}, T_A = 25^\circ \text{C}$.

NOTE 2: I_{CC} is measured with all outputs open and inputs at 4.5 V.

switching characteristics, $V_{CC} = 5 \text{ V}, T_A = 25^\circ \text{C}$

PARAMETER		TEST CONDITIONS	MIN	TYP	MAX	UNIT
t_{PHL}	Propagation delay time, high-to-low-level output from A input	$C_L = 15 \text{ pF}, R_L = 2 \text{ k}\Omega,$			100	ns
t_{PLH}	Propagation delay time, low-to-high-level output from A input	See Note 3			100	
t_{PHL}	Propagation delay time, high-to-low-level output from \overline{RBI} input	$C_L = 15 \text{ pF}, R_L = 6 \text{ k}\Omega,$			100	ns
t_{PLH}	Propagation delay time, low-to-high-level output from \overline{RBI} input	See Note 3			100	

NOTE 3: See General Information Section for load circuits and voltage waveforms.

TTL DEVICES

